



DEPARTMENT OF THE ARMY
U.S. ARMY CORPS OF ENGINEERS
SAVANNAH DISTRICT
100 WEST OGLETHORPE AVENUE
SAVANNAH, GEORGIA 31401-3604

June 1, 2022

Regulatory Division
SAS-2020-00924

JOINT PUBLIC NOTICE
Savannah District/State of Georgia

The Savannah District has received an application for a Department of the Army Permit, pursuant to Section 404 of the Clean Water Act (33 U.S.C. § 1344), as follows:

Application Number: SAS-2020-00924

Applicant: Mr. Christopher Novack
Georgia Ports Authority (GPA)
Post Office Box 2406
Savannah, Georgia 31402

Agent: Mr. Brandon Wall
Sligh Environmental Consultants, Inc.
31 Park of Commerce Way, Suite 200B
Savannah, Georgia 31405

Project Purpose as Proposed by Applicant: The applicant's stated project purpose is *"to provide additional container storage capacity at Garden City Terminal in order to reduce congestion and improve operations at the terminal and to accommodate growth in container volumes."*

Location of Proposed Work: The project site is located adjacent to GPA's Garden City Terminal (GCT), east of Jimmy DeLoach Parkway, north of Bourne Avenue (Highway 307), and approximately 0.5 mile west of State Route (SR) 25, in Chatham County, Georgia (Latitude 32.1298, Longitude -81.1612). The aquatic resources located on-site drain to the Savannah River, a Traditional Navigable Waterway (TNW).

Description of Work Subject to the Jurisdiction of the U.S. Army Corps of Engineers: The applicant is proposing to modify an existing permit. The original permit consisted of the fill 13.351 acres of wetland, 3.612 acres of open water ponds, and 1,383 linear feet of ditch as well as the excavation of 1.537 acres of wetland associated with the expansion of the GCT container yard. The modification would consist of the fill of an additional 1.711 acres of wetland while avoiding 0.05-acre of previously permitted fill. For wetland excavation, the applicant proposes an additional

0.703-acre of impact while avoiding 0.047-acre that was previously permitted and the fill of an additional 79 feet of ditch while avoiding 537 feet of ditch that was previously permitted.

To offset the loss in aquatic function associated with the additional impacts, the applicant has proposed the purchase of 9.28 wetland credits (for a total of 31.68 wetland credits) from a U.S. Army Corps of Engineers approved mitigation bank that services the Lower Savannah watershed (HUC 03060109).

BACKGROUND

Existing Conditions: The project site is an approximately 96.3 acre portion of property previously owned by PCS Nitrogen, Inc. which was purchased by the applicant in December 2019. From the 1950's until the early 2000's, the site contained a rail-served industrial facility that produced nitrogen fertilizers and feed ingredients. The site was decommissioned in the early 2000's, and most of the manufacturing facilities were removed. The remainder of the office buildings, sheds, and other structures were demolished in 2009. Today, the site contains the remnants of the concrete building pads, roads, and rail that used to exist.

As proposed, the project would expand the GCT. GCT is GPA's dedicated container terminal with the vast majority of cargo coming in and out of the terminal in containers. Both loaded and empty containers arrive and depart from the terminal each day by different modes of transportation including ship, truck, rail, community, and internal strip moves. The terminal has multiple truck gates which service thousands of trucks each day as well as a major multi-modal rail facility just to the east of the project site which services both CSX Transportation and Norfolk Southern (NS). The terminal totals approximately 1,345 acres and extends along the Savannah River from Brampton Road north to Grange Road.

On the terminal, the space nearest the berths is the most "valuable." This is where the large container storage yards are located, and they are reserved for containers loaded full of goods and commodities ready for export or import. Loaded containers are typically kept near the wharfs to make loading and unloading ships as fast and efficient as possible. Unloaded containers are also shipped in much the same way as loaded containers: on trains, trucks, and ships but are typically kept farther away from the berths. Likewise, other support services such as offices, warehouses, equipment areas, etc. are sited farther away from the valuable wharf space reserved for loaded containers.

Project History: On March 15, 2022, the Corps issued DA authorization to fill 13.351 acres of wetland, 3.612 acres of open water ponds, and 1,383 linear feet of ditch as well as the excavation of 1.537 acres of wetland associated with the expansion of the Garden City Terminal (GCT) container yard. According to the applicant, *“at the end of the planning stages of the project, it was discovered that a new power substation had to*

be constructed on-site due to the power requirements of the electric rubber-tired-gantry (RTG) cranes used to load and off-load containers from trucks and rail. Additionally, final design measures required adjustments to the permitted impact areas.”

This Joint Public Notice announces a request for authorizations from both the Corps and the State of Georgia. The applicant's proposed work may also require local governmental approval.

STATE OF GEORGIA

Water Quality Certification: The Georgia Department of Natural Resources, Environmental Protection Division will review the proposed project for water quality certification, in accordance with the provisions of Section 401 of the Clean Water Act. Prior to issuance of a Department of the Army permit for a project location in, on, or adjacent to the waters of the State of Georgia, review for Water Quality Certification is required. A reasonable period of time, which shall not exceed one year, is established under the Clean Water Act for the State to act on a request for Water Quality Certification, after which, issuance of such a Department of the Army permit may proceed. The applicant has requested a pre-certification meeting with Georgia EPD under Section 401 of the Clean Water Act. The applicant must still request a meeting with EPD at least 30 days prior to any request they make for 401 Water Quality Certification.

State-owned Property and Resources: The applicant may also require assent from the State of Georgia, which may be in the form of a license, easement, lease, permit or other appropriate instrument.

Georgia Coastal Management Program: Prior to the Savannah District Corps of Engineers making a final permit decision on this application, the project must be certified by the Georgia Department of Natural Resources, Coastal Resources Division, to be consistent with applicable provisions of the State of Georgia Coastal Management Program (15 CFR 930). Anyone wishing to comment on Coastal Management Program certification of this project should submit comments in writing within 30 days of the date of this notice to the Federal Consistency Coordinator, Coastal Management Program, Coastal Resources Division, Georgia Department of Natural Resources, One Conservation Way, Brunswick, Georgia 31523-8600 (Telephone 912-264-7218).

U.S. ARMY CORPS OF ENGINEERS

The Savannah District must consider the purpose and the impacts of the applicant's proposed work, prior to a decision on issuance of a Department of the Army permit.

Cultural Resources: A Phase I cultural and archeological resources survey and assessment of effects was prepared and coordinated with the Georgia State Historic Preservation Officer (SHPO) during the initial permit evaluation. The applicant has indicated that they are preparing an updated assessment of effects and will submit it to the Corps for review and coordination with the SHPO.

Endangered Species: A preliminary review the U.S. Fish and Wildlife Service (FWS) list of Endangered and Threatened Species (IPaC) indicates the following listed species may occur in the project area: Eastern black rail (*Laterallus jamaicensis spp.*); wood stork (*Mycteria Americana*); Eastern Indigo snake (*Drymarchon corais couperi*), gopher tortoise (*Gopherus polyphemus*); frosted flatwoods salamander (*Ambystoma cingulatum*) and pondberry (*Lindera melissafolia*).

Pursuant to Section 7(c) of the Endangered Species Act of 1973, as amended (16 U.S.C. § 1531 et seq.), we request information from the U.S. Department of the Interior, Fish and Wildlife Service, the U.S. Department of Commerce, National Oceanic and Atmospheric Administration, National Marine Fisheries Service; or, any other interested party, on whether any species listed or proposed for listing may be present in the area. In addition, we are requesting information from the FWS whether the project is within 2,500 feet of an active wood stork nesting colony.

Public Interest Review: The decision whether to issue a permit will be based on an evaluation of the probable impact including cumulative impacts of the proposed activity on the public interest. That decision will reflect the national concern for both protection and utilization of important resources. The benefit, which reasonably may be expected to accrue from the proposal, must be balanced against its reasonably foreseeable detriments. All factors, which may be relevant to the proposal will be considered including the cumulative effects thereof; among those are conservation, economics, aesthetics, general environmental concerns, wetlands, historic properties, fish and wildlife values, flood hazards, flood plain values, land use, navigation, shoreline erosion and accretion, recreation, water supply and conservation, water quality, energy needs, safety, food and fiber production, mineral needs, considerations of property ownership and in general, the needs and welfare of the people.

Consideration of Public Comments: The Corps is soliciting comments from the public; federal, state, and local agencies and officials; Native American Tribes; and other interested parties in order to consider and evaluate the impacts of this proposed activity. Any comments received will be considered by the Corps to determine whether to issue, modify, condition or deny a permit for this proposal. To make this decision, comments are used to assess impacts on endangered species, historic properties, water quality, general environmental effects, and the other public interest factors listed

above. Comments are used in the preparation of an Environmental Assessment and/or an Environmental Impact Statement pursuant to the National Environmental Policy Act. Comments are also used to determine the need for a public hearing and to determine the overall public interest of the proposed activity.

Application of Section 404(b)(1) Guidelines: The proposed activity involves the discharge of dredged or fill material into the waters of the United States. The Savannah District's evaluation of the impact of the activity on the public interest will include application of the guidelines promulgated by the Administrator, Environmental Protection Agency, under the authority of Section 404(b) of the Clean Water Act.

Public Hearing: Any person may request, in writing, within the comment period specified in this notice, that a public hearing be held to consider this application for a Department of the Army permit. Requests for public hearings shall state, with particularity, the reasons for requesting a public hearing. The decision whether to hold a public hearing is at the discretion of the District Engineer, or his designated appointee, based on the need for additional substantial information necessary in evaluating the proposed project.

Comment Period: Anyone wishing to comment on this application for a Department of the Army permit should submit comments by email to sarah.e.wise@usace.army.mil. Alternatively, you may submit comments in writing to the Commander, U.S. Army Corps of Engineers, Savannah District, Attention: Sarah E. Wise, 100 West Oglethorpe Avenue, Savannah, Georgia 30401, no later than 15 days from the date of this notice. Please refer to the applicant's name and the application number in your comments.

If you have any further questions concerning this matter, please contact Ms. Sarah E. Wise, Team Lead, Coastal Branch at 912-652-5550.

Enclosures:

1. Storage Development, Garden City Terminal, Sheets 1-6, dated March 22, 2022.

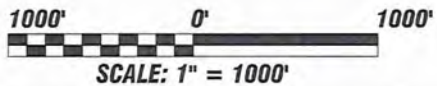
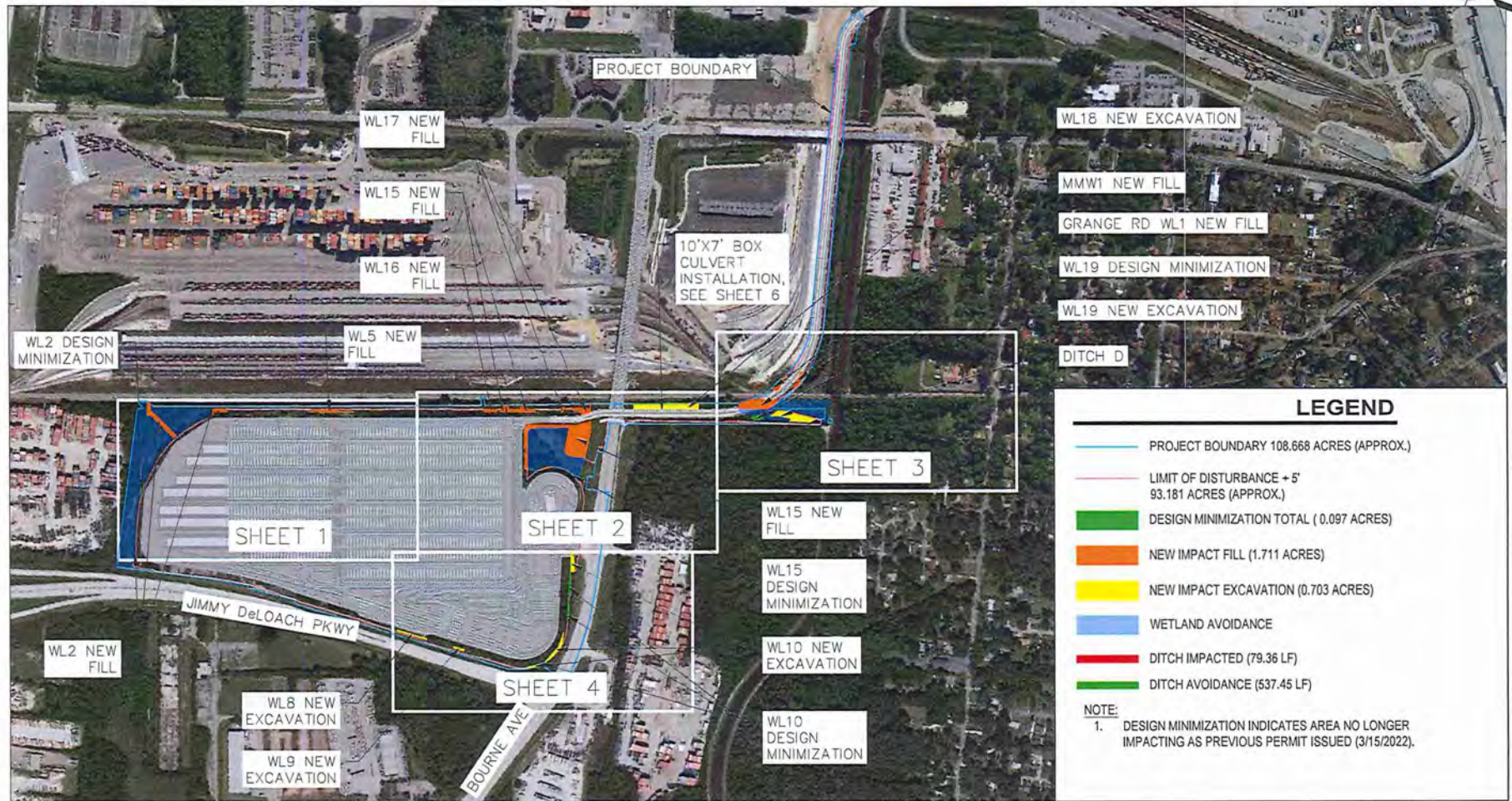

PLAN VIEW

PROPOSED ACTIVITY: ROAD CONSTRUCTION AND STORAGE LOT

DATUM: NAVD 88

NOT FOR CONSTRUCTION

OVERVIEW AND KEY MAP

**WEST EXPANSION
GARDEN CITY TERMINAL
SAVANNAH, GEORGIA 31407**

**STORAGE DEVELOPMENT
GARDEN CITY TERMINAL**

**COUNTY OF: CHATHAM STATE: GEORGIA
APPLICATION BY: GEORGIA PORTS AUTHORITY**

SHEET 1 of 6

DATE: March 22, 2022



LEGEND

- PROJECT BOUNDARY 108.668 ACRES (APPROX.)
- LIMIT OF DISTURBANCE + 5' 93.181 ACRES (APPROX.)
- DESIGN MINIMIZATION TOTAL (0.005 ACRES)
- NEW IMPACT FILL (0.209 ACRES)
- WETLAND AVOIDANCE

NOTE:
 1. DESIGN MINIMIZATION INDICATES AREA NO LONGER IMPACTING AS PREVIOUS PERMIT ISSUED (3/15/2022).

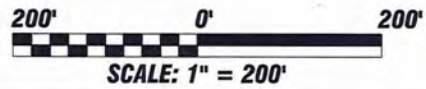

PLAN VIEW

PROPOSED ACTIVITY: ROAD CONSTRUCTION AND STORAGE LOT

DATUM: NAVD 88

NOT FOR CONSTRUCTION

KEY SHEET 1

**WEST EXPANSION
 GARDEN CITY TERMINAL
 SAVANNAH, GEORGIA 31407**

**STORAGE DEVELOPMENT
 GARDEN CITY TERMINAL**

COUNTY OF: CHATHAM

STATE: GEORGIA

APPLICATION BY: GEORGIA PORTS AUTHORITY

SHEET 2 of 6

DATE: March 22, 2022

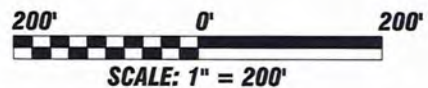

PLAN VIEW

PROPOSED ACTIVITY: ROAD CONSTRUCTION AND STORAGE LOT

DATUM: NAVD 88

NOT FOR CONSTRUCTION

KEY SHEET 2

**WEST EXPANSION
 GARDEN CITY TERMINAL
 SAVANNAH, GEORGIA 31407**

**STORAGE DEVELOPMENT
 GARDEN CITY TERMINAL**

**COUNTY OF: CHATHAM STATE: GEORGIA
 APPLICATION BY: GEORGIA PORTS AUTHORITY**

SHEET 3 of 6

DATE: March 22, 2022

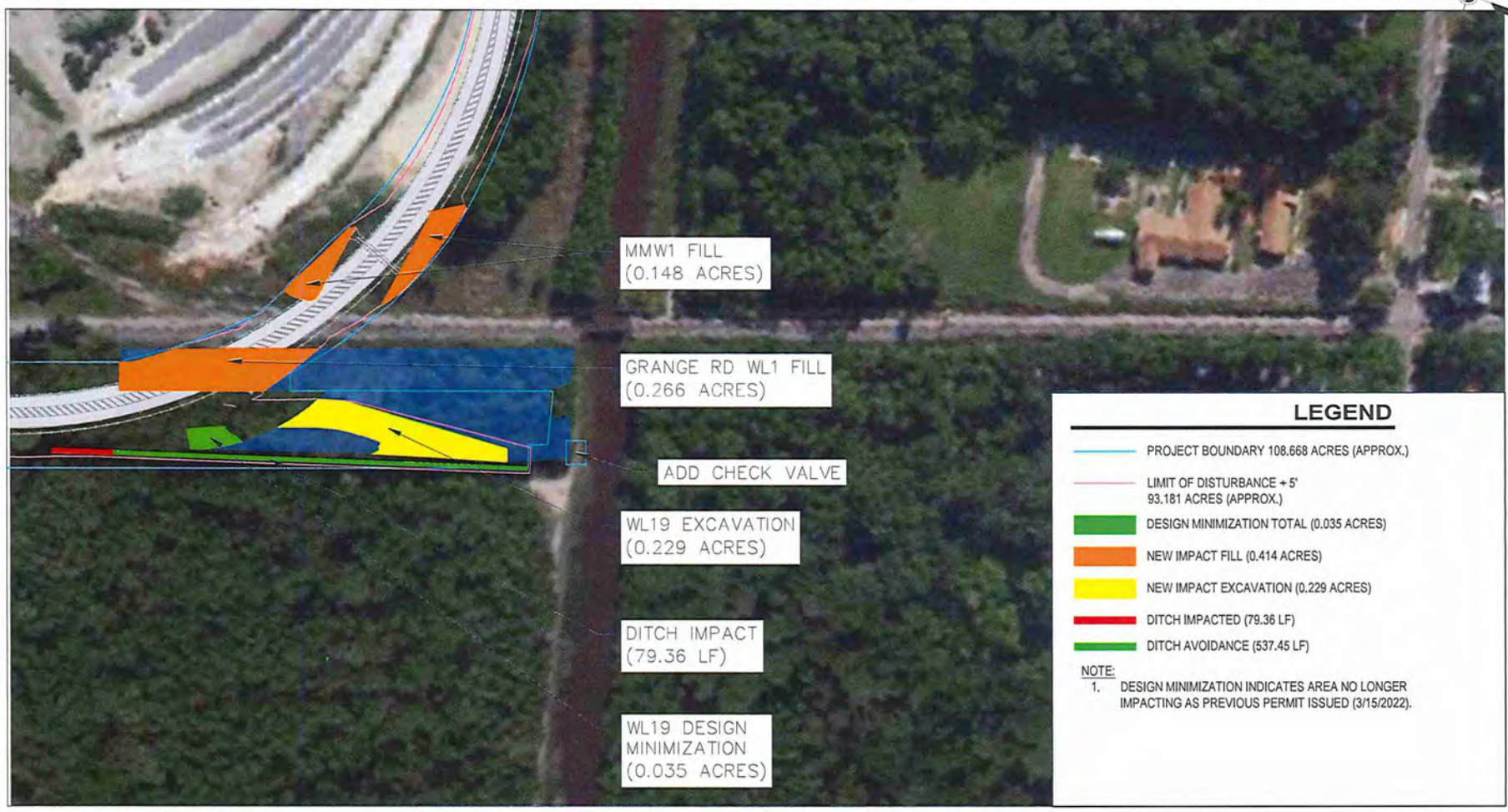

MMW1 FILL
(0.148 ACRES)

GRANGE RD WL1 FILL
(0.266 ACRES)

ADD CHECK VALVE

WL19 EXCAVATION
(0.229 ACRES)

DITCH IMPACT
(79.36 LF)

WL19 DESIGN
MINIMIZATION
(0.035 ACRES)

LEGEND

- PROJECT BOUNDARY 108.668 ACRES (APPROX.)
- LIMIT OF DISTURBANCE + 5'
93.181 ACRES (APPROX.)
- █ DESIGN MINIMIZATION TOTAL (0.035 ACRES)
- █ NEW IMPACT FILL (0.414 ACRES)
- █ NEW IMPACT EXCAVATION (0.229 ACRES)
- █ DITCH IMPACTED (79.36 LF)
- █ DITCH AVOIDANCE (537.45 LF)

NOTE:

1. DESIGN MINIMIZATION INDICATES AREA NO LONGER IMPACTING AS PREVIOUS PERMIT ISSUED (3/15/2022).

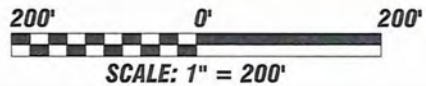

PLAN VIEW

PROPOSED ACTIVITY: ROAD CONSTRUCTION AND STORAGE LOT

DATUM: NAVD 88

NOT FOR CONSTRUCTION

KEY SHEET 3

**WEST EXPANSION
GARDEN CITY TERMINAL
SAVANNAH, GEORGIA 31407**

**STORAGE DEVELOPMENT
GARDEN CITY TERMINAL**

COUNTY OF: CHATHAM

STATE: GEORGIA

APPLICATION BY: GEORGIA PORTS AUTHORITY

SHEET 4 of 6

DATE: March 22, 2022

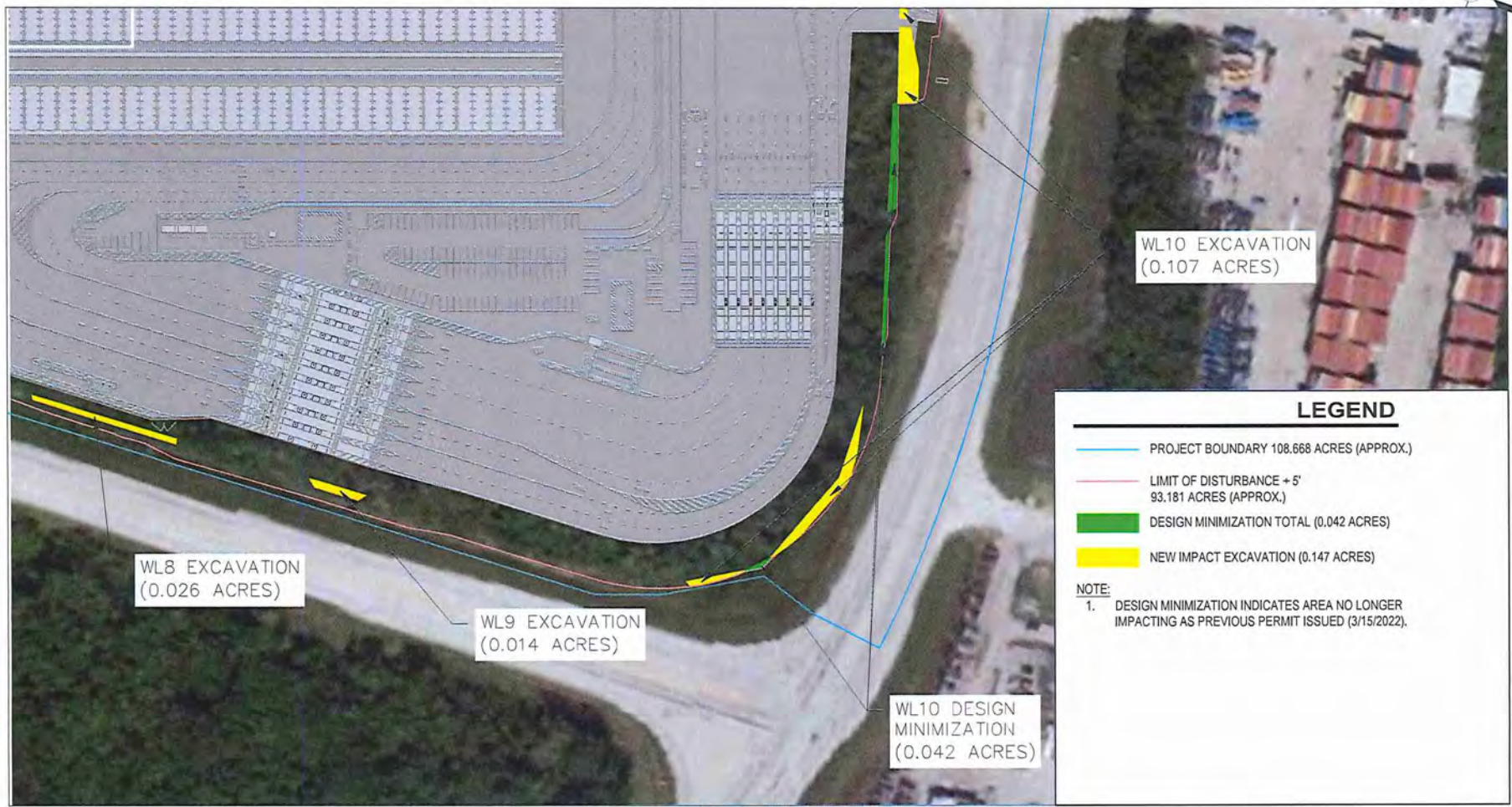

WL10 EXCAVATION
(0.107 ACRES)

WL8 EXCAVATION
(0.026 ACRES)

WL9 EXCAVATION
(0.014 ACRES)

WL10 DESIGN
MINIMIZATION
(0.042 ACRES)

LEGEND

- PROJECT BOUNDARY 108.668 ACRES (APPROX.)
- LIMIT OF DISTURBANCE + 5'
93.181 ACRES (APPROX.)
- DESIGN MINIMIZATION TOTAL (0.042 ACRES)
- NEW IMPACT EXCAVATION (0.147 ACRES)

NOTE:
1. DESIGN MINIMIZATION INDICATES AREA NO LONGER IMPACTING AS PREVIOUS PERMIT ISSUED (3/15/2022).

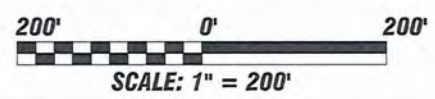

PLAN VIEW

PROPOSED ACTIVITY: ROAD CONSTRUCTION AND STORAGE LOT

DATUM: NAVD 88

NOT FOR CONSTRUCTION

KEY SHEET 4

**WEST EXPANSION
GARDEN CITY TERMINAL
SAVANNAH, GEORGIA 31407**

**STORAGE DEVELOPMENT
GARDEN CITY TERMINAL**

**COUNTY OF: CHATHAM STATE: GEORGIA
APPLICATION BY: GEORGIA PORTS AUTHORITY**

SHEET 5 of 6

DATE: March 22, 2022

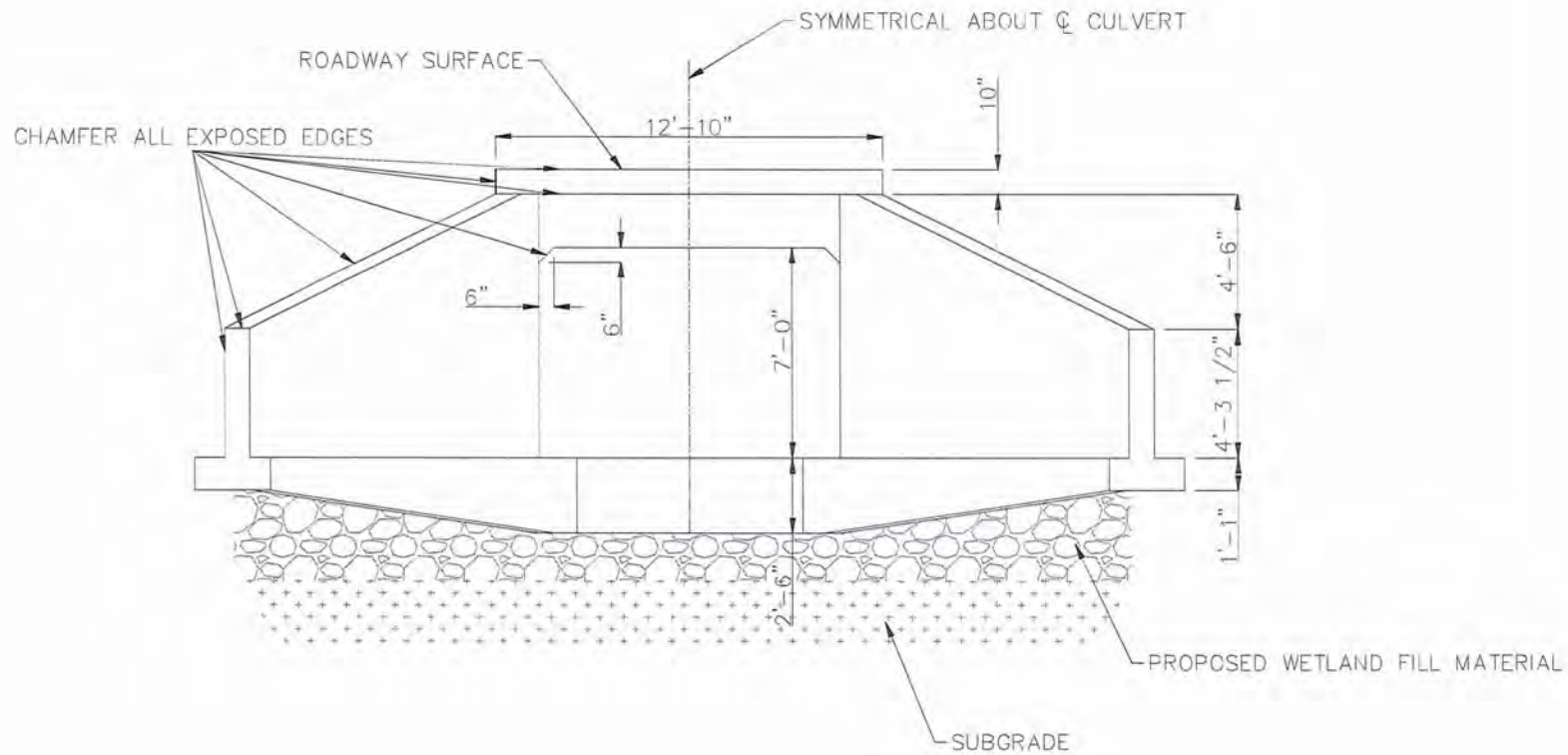

10' X 7' BOX CULVERT - END ELEVATION

SCALE: NOT TO SCALE

PROPOSED ACTIVITY: ROAD CONSTRUCTION AND STORAGE LOT

DATUM: NAVD 88

NOT FOR CONSTRUCTION

ROADWAY BOX CULVERT DETAILS

**WEST EXPANSION
GARDEN CITY TERMINAL
SAVANNAH, GEORGIA 31407**

**STORAGE DEVELOPMENT
GARDEN CITY TERMINAL**

**COUNTY OF: CHATHAM STATE: GEORGIA
APPLICATION BY: GEORGIA PORTS AUTHORITY**

SHEET 6 of 6

DATE: March 22, 2022