

An AREVA and Siemens Company

**NEW SAVANNAH BLUFF
LOCK AND DAM
PROJECT SAVANNAH RIVER
GEORGIA AND SOUTH CAROLINA
FISH PASSAGE FACILITY
ENGINEERING REPORT**

**Prepared for:
U.S. ARMY CORPS OF ENGINEERS**



**Prepared by:
FRAMATOME ANP DE&S, INC.**

December 2002



A
FRAMATOME ANP
FRAMATOME ANP DE&S



FRAMATOME ANP

An AREVA and Siemens Company

FRAMATOME ANP DE&S

December 16, 2002

HV02170

Attention: Mr. William Lynch
CESAS-PM-C

US Army Corps of Engineers - Savannah District
100 West Oglethorpe Ave.
Savannah, GA 31041

Re: New Savannah Bluff Lock & Dam Fish Bypass System
Engineer Report 35 Percent Design – Final Submittal
Purchase Order No. DACW01-00-D-0019

Dear Mr. Lynch:

As discussed during our meeting on December 4, 2002 with the City of Augusta, enclosed please find:

- Thirty (30) hard copies of the Final Engineering Report complete with text, drawings & figures, and
- A compact disc with the subject report in pdf format and drawings SAVANNAH 1 THRU SAVANNAH 6 and Boring Drawings Plate C4-1 & C4-2 in dgn format.

Please note per copy of this letter, I am also forwarding two (2) hard copies of the report and an identical compact disc to Mr. Maurice James, USACE Mobile District. It has been a pleasure to work with the U.S Army Corps of Engineers on this project and we look forward to future opportunities.

Please let me know if you have any questions or need additional information.

Respectfully Submitted,

Ron Grady, PE
Hydropower & Natural Resources

Attachments

Cc w/Attachments: Mr. Maurice James (Two Copies)
Mr. Steve Arnold (Two Copies)
Mr. Jon Truebe (One Copy)
Project File (One Copy)

Table of Contents

I	Introduction	1
A.	Study Authority	1
B.	Study Objectives	1
C.	Project Overview	3
D.	Project Ownership	5
E.	Authorized Project Purpose	5
F.	Authorized Project Uses	5
II	Previous Studies	7
A.	Section 216 Disposition Study, September 8, 2000	7
B.	Section 216 Disposition Study, July 2001 Addendum	8
C.	New Savannah Bluff Lock and Dam, Savannah River Georgia and South Carolina, Fish Passage Report, August 2002	8
III	Site Description	12
A.	Project Site Description Relative to Fish Passage	12
B.	Field Investigations	12
C.	Hydraulic Conditions	13
D.	Current / Future Project Operations	14
IV	Feasibility Design	15
A.	General Boundary Conditions	15
A.1	Design Criteria & Characteristics	15
A.2	Design Fishway Capacity	16
A.3	Design Flow Requirements	17
A.4	Design Pond Elevations	17
B.	Project Configuration Studies and Results	18
B.1	Rock Ramp Channel and Weir Configuration	18
B.2	Headwater Control Structure	26
B.3	On-Site Access	37
B.4	Off-Site Access	38
B.5	Security	38
B.6	Construction Methodology	38
B.7	Testing, Commissioning and Evaluation Criteria	39
B.8	Operations and Maintenance	340
V	Construction Schedule	41
VI	Cost Estimate	42
A.	Material Quantity Estimate	42
B.	Other Issues That Could Effect Installed Cost	43
C.	Cost Estimate	43
VII	Study Conclusions and Recommendations	44

List of Figures

Figure No. 1	Savannah River Profile
Figure No. 2	Typical Velocity Profile in a Stream
Figure No. 3	Typical Channel Section Across the Flow
Figure No. 4	Typical Boulder Layout
Figure No. 5	Typical Section & Boulder Layout Looking Downstream
Figure No. 6	Relationship of Manning to Size of Stone
Figure No. 7	Average Velocity Against Stone on Channel Bottom
Figure No. 8	Equivalent Diameter of Stone vs. Allowable Velocity
Figure No. 9	Typical Boulder Loading Sketch

List of Tables

Table No. 1	Summary of Fishway Design Alternatives
-------------	--

List of Appendices

Appendix No. A	Drawings
Appendix No. B	Boring Logs
Appendix No. C	Site Photographs
Appendix No. D	Material Quantity Estimates
Appendix No. E	Hydrology
Appendix No. F	Meeting Minutes
Appendix No. G	Correspondence
Appendix No. G.1	Mr. Ben Rizzo October 25, 2000 Memo to Mr. Steve Gilbert
Appendix No. H	Headwater Control Structure Calculations
Appendix No. I	Head Gate Information
Appendix No. J	Internal Technical Review
Appendix No. K	Other Fish Bypass System Installations

I Introduction

A. Study Authority

This report has been prepared by Framatome ANP DE&S, together with its subcontractor Lakeside Engineering, Inc. This engineering report contains the results of a study undertaken to assess the technical feasibility of a fish bypass system and to complete project design to a level of approximately 35 percent. The "Terms of Reference" for this design effort was issued by the U.S Army Corps of Engineers (USACE). The authorization to begin work was issued September 9, 2002 via Purchase Order DACW01-00-D-0019.

B. Study Objectives

Background Information

Task order (DACW01-00-D-0019) was issued for **Phase II** of the feasibility study to develop the fish passage element of the New Savannah Bluff Lock & Dam Repair and Rehabilitation Project.

In general, this complete effort was divided into two phases. **Phase I** (Completed on July 19, 2002) included a review of project design activities to date (Section 216 Disposition Study), identification of alternative fishway configurations, preliminary screening and ranking of the alternatives. Conceptual designs of the most promising fishway alternatives were developed to accommodate a rough order of magnitude (ROM) cost estimate of each alternative that passed the initial evaluation. Consultation with appropriate Federal and State regulatory agencies, and selection of a recommended alternative were the final steps of **Phase I**.

Phase II, completed under this task order, includes feasibility level (30 to 35 percent) design of the selected rock ramp fishway alternative in sufficient detail to accommodate a MCACES based cost estimate and operation & maintenance costs. Design activities for the selected rock ramp fishway alternative are in general conformance with Engineering and Design for Civil Works Projects (USACE, ER 1110-2-1150) as directed by the Contracting Officer's Representative (COR) with consultation from the Savannah and Mobile Districts USACE project staffs.

Overall Project Objectives

Listed below are the overall project objectives.

- Provide engineering data (including quantities for excavation, fill and construction materials) and analysis sufficient to develop a feasibility level project schedule (by others) and cost estimate (by others).
- Assist the USACE Project Delivery Team (PDT) in the development of a complete project schedule and schedule of funds needed for final design and construction.
- Develop a preliminary design of the recommended plan to the level required to ensure that the design can be implemented without the need for major revisions and that the baseline cost estimate is adequate.

- Determine the relative engineering requirements for various structural and nonstructural elements.
- Develop design studies and operational plan requirements.
- Establish and describe the basic configuration of all structural elements including plan, profiles and basic project details to a feasibility level.
- Provide sufficient information to establish real estate requirements.
- Identify borrow and disposal requirements, easements and right-of-ways for the proper disposal of dredged or excavated material.
- Generate a detailed engineering appendix for the feasibility report complete with drawings, attachments, etc.
- Develop baseline project performance requirements

Feasibility Design Development

In accordance with the above stated objectives, this feasibility level design (30 - 35 percent) effort was performed for the USACE selected rock ramp fish passage system at the New Savannah Bluff Lock and Dam (NSBL&D). This design effort was executed in accordance with the following five (5) primary tasks:

- Task 1** *Preferred Project Layout & Report Outline* - Perform studies and engineering analysis to establish the preferred project layout, including plans, profiles and basic details of the rock ramp fish passage configuration and appurtenant structures. This effort shall include identification, design and description of any modifications of the existing structure to ensure the performance of the fish passage. Design of any modifications to the existing structure will also be carried to the feasibility (35%) level.
- Task 2** *Submit General Arrangement Drawings and Report Outline* - Submittal of Preliminary General Arrangements Drawings and Feasibility Report Annotated Outline to USACE for review and comment.
- Task 3** *Draft Engineering Appendix for Feasibility Design Report and Detailed Layout Drawings* – Complete feasibility level design and generate a draft engineering appendix complete with project drawings in sufficient detail to support the development of reliable project schedules and baseline cost estimates with reasonable and acceptable accuracy. The engineering appendix and associated drawings will be submitted to the USACE for distribution to the Agencies for pre-meeting review. It is also anticipated that the USACE will utilize this submittal to facilitate any necessary internal technical reviews by the Project Delivery Team (PDT) and an Independent Technical Review (ITR) board.
- Task 4** *Agency Consultation/USACE Internal Review Meetings* - Participate in a one day Agency consultation meeting with the USACE to present and seek Agency consensus for the final project configuration. As part of the Agency coordination, the A-E may be required to participate in a review meeting as requested by the COR. This meeting will be held at the same location as the Inter-Agency meeting.

Task 5 Document Revisions and Final Report Submittal - The engineering appendix for the feasibility report and associated drawings will be revised as directed by the COR to reflect agency comments and recommendations emanating from the USACE internal technical review process. Post document revisions, a final report will be submitted.

C. Project Overview

The New Savannah Bluff Lock and Dam (NSBL&D) is located along the Savannah River, at River Mile 187.4, approximately 13 river miles downstream from the City of Augusta in Richmond County, Georgia and the City of North Augusta in Aiken County, South Carolina. The project constitutes the first and most downstream lock and dam facility along the Savannah River. The following facilities are located upstream of the NSBL&D (Refer to Figure No 1):

Facility	River Mile
Augusta City Lock & Dam	207.2
Stevens Creek Dam	208.1
J. Strom Thurmond Project	220.9

The NSBL&D facility was constructed by the U.S. Army Corps of Engineers and consists of a lock chamber, dam, operations building, and a 50-acre park/recreation area. Construction of the Project was completed in 1937. The dam structure is 360 feet long and contains five vertical spillway gates. Each gate bay is 60 feet long and located between concrete piers. The gates on each end of the dam spillway are overflow type and measure 12 feet tall. The three middle spillway gates are 15 feet tall and are non-overflow type. All of the spillway gates are remotely operated from the J. Strom Thurmond Hydroelectric Facility located upstream. The lock is located along the right abutment (Georgia Side) and measures approximately 56 feet wide and 360 feet long, with a maximum lift height of approximately 15 feet.

Presently, the facility provides ponding upstream to support several water intakes and recreation. While commercial traffic no longer passes through the Project lock, some small recreation vessel locking is provided. The facility provides little in the way of flow retention or river regulation.

Map

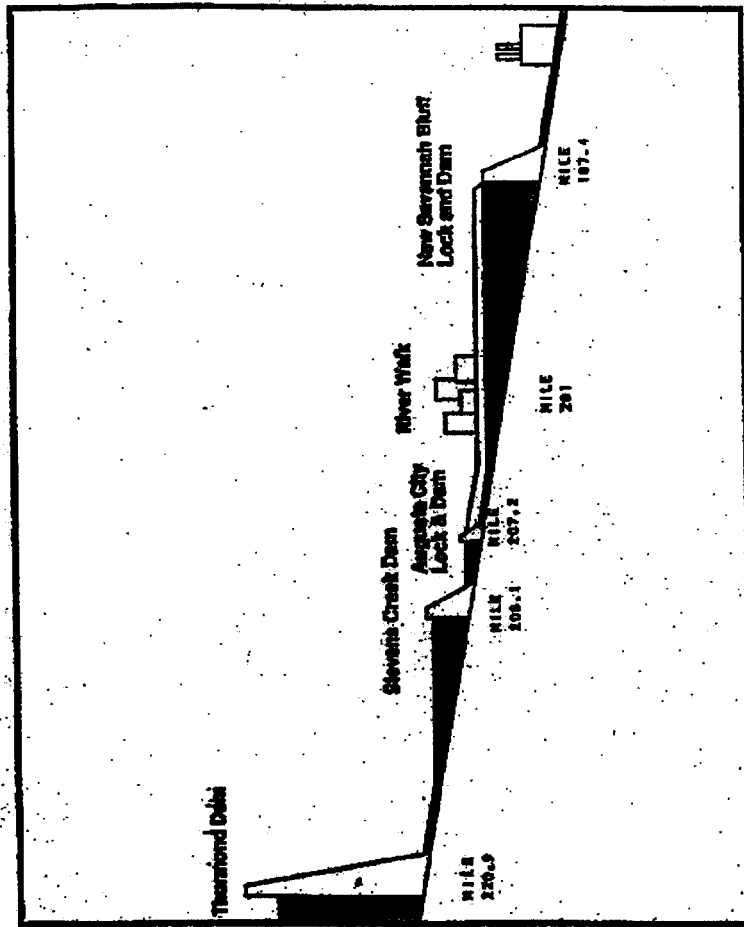

FIGURE 1. SAVANNAH RIVER PROFILE IN THE VICINITY OF THE NEW SAVANNAH BLUFF LOCK & DAM.

D. Project Ownership

This project was constructed by the U.S. Army Corps of Engineers, Savannah District, and is owned by the Federal Government. In response to recent Congressional direction (see Section II B), the USACE has been instructed to fully repair the lock and dam and provide fish passage, and to subsequently transfer ownership of the Project to the City of North Augusta and Aiken County, South Carolina.

E. Authorized Project Purpose

The NSBL&D project was authorized for the sole purpose of improving the commercial navigation channel between the upper limits of the Savannah Harbor and the head of navigation at Augusta, Georgia. It was a modification to the existing Savannah River below Augusta (SRBA) navigation project.

F. Authorized Project Uses

This project improved the commercial navigation channel for the SRBA project by way of its lock facilities and provided a 9-foot navigation channel between the upper limits of the Savannah Harbor and the head of navigation at Augusta, Georgia.

The project has not served commercial navigation since 1979 and no longer regulates downstream flows for navigation. In 1987, the public park and recreation facility and the lock were leased to the City of Augusta *"for purposes of operation and maintenance of the Project"*.

Although the Savannah District no longer operates the lock, it continues to operate the vertical lift gates of the dam to manage pool elevations for incidental uses such as water supply and water-related recreation. The vertical lift gates are remotely operated 6 to 18 times a week during normal conditions to control the elevation of the pool.

The Savannah District also operates this project in conjunction with the J. Strom Thurmond project to pass some migrating anadromous fish species. Large releases, of 16,000 cfs, are made from the J. Strom Thurmond project usually during the first week of May, but only if there is excess water in the J. Strom Thurmond reservoir that must be released. This enables some migrating anadromous fish species to pass under the vertical lift gates and over the sill of the NSBL&D. During drought years, this operation usually cannot be conducted. During normal to high flow years, it generally is conducted.

Augusta-Richmond County operates the lock to pass migrating fish species, as required, under an existing lease agreement. Between 30 and 50 lock cycles are performed annually during the period of March 15 and June 15 for the purpose of fish passage. They also operate the lock between 50 to 100 cycles per year for recreational boating traffic.

On December 8, 1998, the Secretary of the Army and Richmond County, Georgia, mutually agreed to amend the existing lease agreement so that:

“Richmond County acting by and through the Mayor of the Augusta-Richmond County Commission is responsible for all operation and maintenance costs of this lock and public park premises until 7 December 2008 and thereafter for so long as the project remains in operation”

II Previous Studies

A. Section 216 Disposition Study, September 8, 2000

The purpose of this study was to review the current uses of the NSBL&D Project, Savannah River, Georgia and South Carolina, and recommend its future disposition. In 1979, the last commercial shipment passed through the NSBL&D project and, consequently, maintenance of the navigation channel was discontinued. Funding for proper maintenance of the lock and dam was curtailed. The current condition of the project is poor. Major repairs and rehabilitation are required to assure a safe and reliable project. The total cost to conduct necessary and immediate repairs and rehabilitation was estimated at \$6,800,000.

Although the project no longer serves commercial navigation, the study determined that the project currently serves water supply users including one municipality, five industries, and one sod farm; water-related recreation opportunities such as general boating and fishing and specialized rowing and powerboat race events; and regional economic development and tourism. It is also operated to pass some migratory anadromous fish species.

During the 216 study period, the Savannah District contacted state and local interests to determine if they were interested in taking over ownership of the project. No entity was interested in taking it over in its present condition. However, in recognition of the significant benefits the project provides to the surrounding area, local interests indicated they would consider accepting ownership if the Federal Government pays for all immediate and necessary repairs and rehabilitation.

This study considered and evaluated four alternatives:

1. Status quo
2. Transfer ownership
3. Reauthorization
4. De-authorization

The report also included a letter proposal by the City of North Augusta and Aiken County, South Carolina, which stipulated their terms for transfer of ownership or reauthorization of this project.

As of the study completion date, a non-Federal entity willing to cost-share immediate repairs and rehabilitation, and pay for all future repairs and rehabilitation of the project had not been identified. Accordingly, the District had no other option but to proceed with a recommendation to Congress for complete removal of the structure at full Federal cost estimated at \$5,350,000 and de-authorization of this feature of the SRBA navigation project.

B. Section 216 Disposition Study, July 2001 Addendum

The purpose of this addendum was to respond to Congressional direction in Section 348(1) of the Water Resources Development Act (WRDA) of 2000, P.L. 106-541, and the Omnibus Appropriations Act, 2001, P.L. 106-554. As a result of the WRDA 2000, Congress has authorized the Savannah District, USACE, to repair and rehabilitate the Project at full Federal cost, provide fish passage, and to subsequently transfer the Project to the City of North Augusta and Aiken County, South Carolina.

During comments on the draft of this addendum, fishery resource agencies indicated they had concern with the fishway design in the original September 8, 2000 216 Study Report. They recommended a full review of fish passage options in collaboration with fishery resource agencies, and if modifications to the original 216 Study fishway design are proposed they will be coordinated with Federal and State fishery resource agencies.

C. New Savannah Bluff Lock and Dam Project, Savannah River Georgia and South Carolina, Fish Passage Report, August 2002.

C.1 Objectives of Study

The basic objectives of this study (Phase I) were to review previous study efforts, identify alternative fish passage configurations, coordinate with various fishery resource agencies to solicit design input, and foster cooperation. Following this information gathering phase, study objectives were to screen and rank the various fish passage alternatives, and select two or three for development to sufficient detail for a rough order of magnitude cost estimate. This first level of fish passage alternative screening was performed in consultation with resource agencies at a meeting held on May 21, 2002. A second round of consultation and review by concerned resource agencies took place during a meeting held on June 26, 2002. The objective of this meeting was to present study conclusions, and to receive resource agency recommendations for the best fishway design alternative to carry forward to the 35 percent design level (Phase II). Additional work scope details, objectives, and consultation meeting minutes are provided in the Phase I report (FANP DE&S 2002).

C.2 Study Methods

Methods employed during the Phase I study were a historical information review, development of contemporary topographic, hydrographic, and subsurface geology data, resource agency consultation including confirmation of design criteria, and a site-specific analysis of fish passage alternatives. Fishway alternatives reviewed included:

- Pool & Weir/Gabion
- Full River Rock Ramp
- European/Natural Channel
- Rock Ramp Gate No. 5
- Rock Ramp Horseshoe SC Side
- Denil Fish Ladder

- Pool & Weir Fish Ladder
- Vertical Slot Fish Ladder
- Fish Passage Via Navigation Lock
- Fish Lock & Lift
- Fish Pump

C.3 Results and Conclusions

A summary matrix of fishway design alternatives considered, are shown in Table 1. The matrix lists the various types of fishway designs considered, down the left side, and many of the important design criteria across the top. This matrix was reviewed with resource agency personnel at the June 26, 2002 consultation meeting held in Savannah, Georgia. The purpose of the meeting was to review the draft (Phase I) report and make recommendations for the preferred design to carry forward to the 35 percent design level.

One of the most important fishway selection criteria for the NSBL&D site is how much operation and maintenance labor would be required to keep the fishway functional. The design options utilizing the existing navigation lock (Table 1, Alternative No. 5.5), individually designed and constructed fish lock or fish lift designs (Alternative No. 5.6), and a fish pump (Alternative No. 5.7), all have relatively high operation and maintenance costs associated with them. All of these designs require some type of mechanical/motorized equipment that must be maintained. These designs also require relatively high labor to operate and monitor performance. Although these designs have proven to be very effective at moving fish with diverse hydraulic requirements at other sites, the high level of operation and maintenance costs preclude them from further consideration.

As discussed in the resource agency communications (B. Rizzo October 25, 2000 memorandum, comments on September 8, 2000, 216 Amendment), the Gabion Pool and Weir design was not well received by resource agency personnel. Concerns were expressed over the hydraulics, stability, and aesthetics of this fishway design. Construction and operation and maintenance labor were also a concern. For these reasons, this design was dropped from further consideration.

The European/Nature-Like Channel design was given serious consideration. However, the space requirements would necessitate additional land purchase (complicated by an unwilling landowner). Additionally, channel stability issues, and operation and maintenance costs precluded this design.

The full river rock ramp shares many of the advantages of the smaller rock ramp designs considered (see below). However, the full river rock ramp requires the complete removal of all five dam gates and supporting structures. This is not an acceptable design because Congressional Project authorization requires the maintenance of the lock and dam structure. Also, the loss of river gated control of pool elevations at the site, and structural issues associated with demolition of the spillway structures, further detract from this alternative.

This process of elimination leaves two basic designs viable for consideration, the smaller rock ramps (either the Gate 5 or the horseshoe – South Carolina shore) and the standard structural swim-through fish ladder designs. These two designs were examined closely. The structural swim-through fish ladders have several baffle designs. However, for the species under consideration, the vertical slot baffle fish ladder is preferred, especially for American shad. Two variations of the small rock ramp are also under consideration, the Gate 5 rock ramp, and the S.C. horseshoe rock ramp.

The rock ramp designs have several advantages over the vertical slot fishway. The rock ramps have a broad range of hydraulic conditions that should accommodate many, if not all of the design target species. Rock ramps will also function well for downstream passage, are not capacity limited (number of fish), and will generally have lower operation and maintenance costs than a vertical slot fishway.

Among the two rock ramp designs, the horseshoe design, avoids dam structural concerns at Gate 5, in-river construction concerns and associated significant construction costs, and offers entrance/exit locations at the dam face for better upstream and downstream fish attraction. Therefore, the horseshoe rock ramp design on the South Carolina shore was selected by the USACE as best suited to the NSBL&D site and will be carried forward to the 35 percent design level.

TABLE 1
SUMMARY OF FISHWAY DESIGN ALTERNATIVES
(DEVELOPED IN PHASE I STUDY)

Type	Phase I Report Reference	Agency Acceptance	Entrance Attraction Flow (cfs)	Transport Water (cfs)	Headpond Fluxation Tolerance	Pass Design Species	Possible Cause of Fish Injury	Capacity (lb/hr)	Continuity of Passage	No. of Pools	Maintenance/ Dependability	Operating Personnel (hr)	Construction Difficulty	Spillway/Dam Loss (ln. ft.)	Aid to Downstream Sturgeon Passage	Notes - Alternatives Evaluation
Pool & Weir/Gabion	5.1	no	600	200	low	most	fallback	medium	yes	17	low/high	Low-medium	high	0	fair	Eliminated-Construction difficulty, low headpond fluctuation tolerance, supplemental attraction flow
Full River Rock Ramp	5.2	yes	full river	full river	medium	yes		unlimited	yes	17+	low/high	low	high	300	good	Eliminated - Loss of dam and pool control, Congressional authorization requires maintaining dam/lock structures
European/Natural Channel	5.3	yes	600	600	medium	yes		high	yes	1	medium/high	low	high	0	no	Eliminated - requires real estate from unwilling landowner, channel stability/maintenance concerns
Rock Ramp Gate No. 5	5.4.1	yes	600	600	medium	yes		high	yes	23+	medium/high	low	medium	60	no	Preferred - may take rock adjustments after initial trials, difficult in-river construction, potential dam stability issues
Rock Ramp Horseshoe SC Side	5.4.2	yes	600	600	medium	yes		high	yes	23+	medium/high	low	medium	0	good	Preferred - may take rock adjustments after initial trials, no in-river construction.
Swim Through Fish Ladder - Demil	5.4.3	no	150	25	3 ft	no	fallback	medium	yes	1	low/high	medium	medium	0	no	Eliminated - won't pass sturgeon and other design species
Swim Through Fish Ladder - Pool & Weir	5.4.3	possible	150-600	60	low	most	fallback	15,000	yes	22	medium/high	medium	medium	0	fair	Eliminated - headwater sensitive, may not pass all design species
Swim Through Fish Ladder - Vertical Slot	5.4.3	yes	600	60	moderate	most	fallback	15,000	yes	22	medium/high	medium	medium	0	good	Preferred - third choice after two rock weir designs, may have effectiveness problems for some target species, higher O&M
Fish Lock Using Navigation Lock (only as an emergency back-up)	5.5	no														Eliminated - Not suitable as primary passage device - high operation labor - Excellent emergency back up fishway.
Mechanically Generated Currents	5.5.1	no	Mechanical flow inducer	One lock cycle	high	yes		unlimited	no	1	medium/medium	high	low	0	fair	Eliminated - High operation labor requirements.
Gravity Flow Gate Manipulation	5.5.2	no	150-600	500	high	yes		unlimited	no	1	medium/medium	high	low	0	fair	Eliminated - High operation labor requirements.
Fish Lift/Fish Lock	5.6	no	150-600	60	high	yes	crowding	15,000	10min/cycle	1	high/medium	high	high	0	no	Eliminated - High operation labor requirements and high O&M requirements.
Fish Pump	5.7	no	150-600	5	unlimited	most	holding in Pipe	28,000	yes	0	high/medium	high	low	0	no	Eliminated - High operation labor requirements and high O&M requirements.

III Site Description

A. Project Site Description Relative to Fish Passage

The NSBL&D at River Mile 187.4 (Refer to Figure No. 1) is the lowest fish barrier on the Savannah River. The 7,508 square mile drainage area has an average river discharge at the site of approximately 9,500 cfs (1952 through 1998). The flows and water elevations, as listed in the USFWS October 25, 2000, Ben Rizzo design memorandum (Appendix G.1), are based on the 1952 through 1998 period of record. It is important to remember the period of record used in the USFWS analysis predates the construction of the Hartwell (1962) and Richard B. Russell (1982) Projects, two major flood control projects in the basin immediately upstream of the J. Strom Thurmond Project.

The normal headwater elevation at NSBL&D is 114.5 feet (NGVD). Headwater control is very good due to the five gates in the spillway that are operated in conjunction with the upstream reservoirs. The dam structure has two fixed crested overflow type gates, one on the Georgia side and one on the South Carolina side of the river, that are 60 feet wide with an overflow invert of 112.0 feet. The center of the dam structure has three 60 feet wide steel lift gates with an invert of 100.5 feet. The low normal tailwater elevation is 101.5 feet and extreme low tailwater is 98 feet. Consequently, a fishway design maximum head of 17.5 feet (which assumes a headwater elevation of 115.5), minimum headwater of 113.5 feet, and normal headwater of 114.5 feet (NGVD) were used for design purposes. The lock chamber is 56 feet wide and approximately 360 feet long. The riverside lock wall extends about 270 feet downstream and 330 feet upstream of the dam respectively.

B. Field Investigations

B.1 Subsurface

In support of this study, seven subsurface borings were conducted under the direction of the USACE along the east abutment (Appendix B, Plates C4-1 & C4-2). According to the boring logs, the material is predominately composed of silt and sand with some traces of mica. The borings were advanced to depths of 18 feet (boring B-14-02, most upstream boring) to 30 feet (boring B-02-02, most downstream boring). The water table varies from around elevation 110 (upstream) to elevation 99 downstream. No rock was encountered within any of the boreholes. Standard Penetration Tests were performed at about 1.5 foot intervals, with blow counts measured from a low of 2 to as high as 27. In general, the material density can be characterized as loose to medium.

From a constructability perspective, common excavation equipment may be utilized with no anticipated blasting. Some water control may be required. However, to eliminate most seepage infiltration, a sheet pile cutoff wall is installed at the upper headwater structure location, extending from the existing dam abutment cutoff wall in an easterly direction to a distance of approximately 30 feet beyond the headwater control structure.

B.2 Fish Studies

Both Georgia DNR and South Carolina DNR have conducted management related studies of fish in the Savannah River near the NSBL&D Project site in recent years. Information from these studies were discussed during the May 21, 2002 consultation meeting, and helped to establish target species and seasonal passage windows. Clemson University has conducted the most recent fishery investigations at the project site in 2001 and 2002. These studies have focused on migratory species approaching the project dam. While these results are not yet published, valuable design information was gleaned from results to date including:

- Upstream fish passage efficiency was estimated for American shad as approximately 60 % in 2001, and less than 40 % in 2002 due to drought and low lock cycling frequencies;
- Observations indicate that fish travel up the Georgia shoreline when approaching the dam, and fish tend to congregate immediately downstream of Gate #5 along the S.C. shoreline.
- Successful radio tagging in 2002 should provide new data on the migration patterns of both shortnose sturgeon and robust redhorse in the near future.

C. Hydraulic Conditions

The hydrology of the lower Savannah River has been substantially modified by the construction of several USACE multipurpose projects that include flood control capacity. These projects include the J. Strom Thurmond Project completed in 1954, the Hartwell Project completed in 1962, and the Richard B. Russell Project completed in 1984.

Headwater, tailwater, and daily discharge data were provided by the USACE for 1992 through April 2002. Percent exceedence curves were generated for each. The results are provided in Appendix E. While the data for the most recent 10-year period reflect current water management practices in the Savannah River basin, they also include several abnormal drought years. Therefore, the 1992 through 2002 period of record may underestimate future hydraulic conditions. The datum for the headwater gage is 100.58 feet (NGVD). The datum for the tailwater gage is 96.58 feet (NGVD). The normal headwater elevation at NSBL&D (50 percent exceedence) is about 114.5 feet, and normal tailwater elevation is about 100.5 feet. Normal head differential is about 14 feet, and maximum head is estimated at approximately 17.5 feet. The Project can control flows up to 20,000 cfs. Above this discharge, all five gates are pulled clear of the water. As river discharge increases, tailwater elevation rises and head decreases. At flows of 25,000 cfs, the head differential can reduce to as little as 6 inches.

Under low flow conditions, the project discharges a minimum downstream flow of 3,600 cfs, generally through gates 1 and 5 (overflow gates) with the remaining flow supplied through gates 2 through 4. Under extreme low flows, Project discharge may be altered, by adjusting gates 2 through 4, in order to meet the target minimum tailwater elevation of 98 feet. All Project gates are operated remotely from the J. Strom Thurmond Project. Under normal conditions, the crest of the two overflow gates remain fixed, and upstream generation flows

are passed by manipulation of gates 2 through 4 to keep the headwater elevation at a constant target pool elevation.

D. Current/Future Project Operations

The five discharge gates and lock facility at the New Savannah Bluff Lock and Dam are currently operated remotely by the U.S. Army Corps of Engineers from the J. Strom Thurmond Project. Gates 1 and 5 are typically operated as fixed overflow gates and 2 through 4 as under flow gates. Additional information is provided in Section III.C of this report. The U.S. Army Corps of Engineers will continue to operate the five discharge gates after Project transfer to the City of North Augusta and Aiken County, South Carolina, with no expected changes on the mode of operations. It should be noted that future lock operations are expected to be infrequent.

IV Feasibility Design

A General Boundary Conditions

A.1 Design Species & Characteristics

Based on site specific sampling and observations by resource agency and Clemson University scientists, the following target species were presented and discussed by fishery resource agency staff at a May 21, 2002, consultation meeting (FANP DE&S 2002):

Species	Typical Size (inches)	Typical Weight (lbs)
Shortnose Sturgeon	18 to 40	3 to 24
Atlantic Sturgeon	24 to 72	10 to 200
American Shad	12 to 28	2 to 4
Hickory Shad	12 to 24	1 to 3
Blueback Herring	10 to 15	0.5
Robust Redhorse	12 to 28	2 to 17
Striped Bass	12 to 60	1 to 40
American Eel (upstream)	2 to 12	0.1 to 0.5
(downstream)	18 to 30	1 to 5

The goal of the resource agencies is to pass all species of fish found in the Savannah River at NSBL&D. However, for the purpose of this fishway bypass system, emphasis will be placed on American shad, sturgeon, robust redhorse, striped bass and American eel. Resource agency personnel concluded if passage is provided for these species, most others will be well served.

Swim speed is an important aspect in the design of a fish passage facility. A variety of factors [water temperature, size of fish, species characteristics of fish, (Clay 1995)] affect the swim speed of target species. Historically, technical fishways have been designed on the basis of burst swim speeds of jumping fish like salmon. However, NSBL&D does not have any target species that jump to progress upstream. Therefore, the intent of this system is to keep water velocities lower than the target species swimming ability and provide adequate resting pools.

While some species may have good swimming potential, species-specific characteristics influence fishway design. Some important species-specific concerns that need to be considered are:

- American shad are easily confused by variable currents and turbulence;
- Atlantic sturgeon have a minimum passage area requirement of 3 feet wide by 2 feet deep (FANP DE&S 2002);

- Striped bass go through fish lifts and locks in large numbers with entrance velocities of 4 to 6 ft/sec; there is some data on passing shortnose sturgeon through a lift (Kynard 1998). In personal communications with Boyd Kynard, he stated that in his experience, shortnose sturgeon in the north have a swimming ability of 1.5 m/s for a distance of 20 meters. On the Connecticut River shortnose sturgeon successfully enter the lift at Holyoke Dam with an average entrance velocity of 2 m/s. However, Kynard stated that the southern shortnose sturgeon is not as good a swimmer, and he feels that a swim speed of 1 m/s over a 20 meter distance would be a more realistic design criteria for Savannah River shortnose sturgeon;
- Because of the flexible timing and unique movement patterns of the catadromous American eel, it was stated at the meeting May 21, 2002 (FANP DE&S 2002) that a fishway specific to eels is not required at this time.

Based on the wide variety of hydraulic design considerations listed above, it is clear that in order for a fishway at NSBL&D to be successful for all the target species, a large variety of hydraulic conditions need to be present in the same fishway. The benefit of a nature-like rock ramp fishway is that it provides a variety of velocities and depth, over a range of flows, to suit the numerous target species. While technical fishways are usually designed to create a very uniform and controlled hydraulic environment to accommodate one species of fish, a nature-like rock ramp fishway is designed to imitate natural stream hydraulics where a broad array of hydraulic conditions are often present in a given channel segment.

In this report, velocities in the rock ramp fishway channel are expressed as an average cross section velocity, however, it is important to keep in mind that point velocities at any given location will vary over a wide range around the average value.

A.2 Design Fishway Capacity

There is currently no determination of the escapement required for fish passage at NSBL&D. USFWS has stated that for American shad, a restored population may be estimated by multiplying available habitat by 50 shad per acre. However, estimates of available habitat have not been made available. Based on the vertical slot fishway layout in the October 25, 2000 DOI memorandum (FANP DE&S 2002), a rough projected capacity can be determined. The DOI design criteria for that fishway was a capacity of about 15,000 pounds of fish per hour. If the DOI standard design criteria is assumed (the fishway is sized to pass 10 percent of the run in one day and 15 percent of the peak day's run in one hour), the vertical slot fishway would accommodate an annual shad run of approximately 200,000 fish. Species overlap would reduce this capacity, but the DOI fishway is sized for the maximum rate of passage during the single peak hour of the year. Utilizing these criteria, it is assumed that sufficient capacity would be available for all species during the remaining time.

Fishway capacity will not be a critical design issue for the nature-like rock ramp fishway. Unlike technical fishways such as lifts that have hopper dimensions and cycling times to consider or ladders that have limited conveyance flow and small slot dimensions to consider, the rock ramp will have a typical channel width of 75 to 90 feet and depths of 3 to 5 feet.

Therefore, the design assumption is that capacity of the rock ramp fishway is well beyond any projected needs and not a design constraint.

A.3 Design Flow Requirements

During the Phase I Feasibility Study effort, it was generally agreed upon that the fishway bypass system should be operational within the following range of river flows:

Minimum River Flow	3,600 cfs	Percent Exceedence ~98 %
Maximum River Flow	20,000 cfs	Percent Exceedence ~ 10 %

The minimum flow requirement at the site is 3,600. At flows greater than 20,000 cfs, all five gates are pulled from the water and head becomes negligible, allowing free up and downstream fish passage past the project site.

Furthermore, a 600 cfs attraction flow (through the fishway) was adopted as the design basis according to resource agency recommendations. The rock ramp fishway is designed to pass a minimum of 600 cfs at low headwater, and passively adjust upward over the design head range as follows:

Upper Pool Elevation (NGVD)	Upper Pool (Gauge Reference)	Resulting Design Attraction Flow (cfs)	Percent Exceedence
115.5 (Maximum Design)	14.92	1,150	15 %
114.5 (Average Design)	13.92	800	50 %
113.5 (Minimum Design)	12.92	600	95 %

The 600 cfs attraction flow is approximately 5 percent of the mean river flow during the upstream spawning migration period (February through June). The attraction flow could be reduced to 5 percent of mean flow during drier seasons. However, since the diversion of water through the fishway does not interfere with lock or other project operations, seasonal adjustments in attraction flow are not anticipated.

A.4 Design Pond Elevations

A.4.1 Upstream

Based on the historic project operation procedure, it is expected that the headwater will be controlled remotely to maintain a head pond target elevation of 114.5 feet, with a normal operating variation between 113.5 feet and 115.5 feet. Resource agency personnel have indicated a concern with the discharge through Gate 5 interfering with attraction flows to the upstream fishway entrance. Gate 5 has a crest elevation of 112.5 feet. Based upon flow depths of 1 foot (at a 113.5 foot pond elevation), 2 feet (at 114.5), and 3 feet (at 115.5), the approximate discharge over the 60 foot wide gate would be 200 cfs, 550 cfs, and 1,000 cfs, respectively. Approach velocities to the gate would be approximately 0.2 fps, 0.5 fps and 0.9 fps, but would dissipate quickly upstream of the gate. Since the field of influence does not go very far upstream of the gate, it is not expected to interfere with fishway attraction flow or result in upstream migrant fallback.

A.4.2 Downstream

The normal Project tailwater elevation is 99.5 feet and the extreme low tailwater elevation is 98.0 feet. On the downstream side of Gate 5, the dam apron and stilling basin is at elevation 90.5 feet. The average discharge velocity across the stilling basin at extreme low tailwater would be approximately 0.35 to 1.8 fps over the expected operating range of gate of Gate 5 described above, and the discharge velocity will decrease as tailwater elevations increase.

B Project Configuration Studies and Results

B.1 Rock Ramp Channel and Weir Configuration

B.1.1 Objectives

The objective of the proposed rock ramp fishway is to provide numerous fish species access to upstream habitat for spawning, feeding, and shelter. To provide this access, the fishway is designed to provide a range of velocities and depths preferred by the target fish species. The fishway is designed to be self-regulating over a 2 foot headwater variation, including a range of river flows from 3,600 to 20,000 cfs. The fishway will also provide an alternative downstream passage route for those fish that reject the high velocity gradient that may exist at the gate structures of the dam.

Although not a design criteria, there is also the potential for some fish species that prefer Piedmont rocky shoal habitat, to spawn or take up residence within the fishway.

B.1.2 General Design Criteria

The following list includes the general target criteria considered during development of the rock ramp fishway design:

- Range of pool depths to accommodate numerous species
- Range of water velocities within the rock ramp to accommodate numerous species
- Zone of passage for sturgeon with no vertical obstruction greater than 9 inches
- Minimum attraction/transport flow of 600 cfs
- Entrance adjacent to Gate Five discharge downstream of entrained air turbulence
- Ramp from tailrace river bed to fishway for bottom moving upstream migrants
- Ramp from fishway to forebay river bed for bottom moving downstream migrants
- Self-regulating over 2 foot headwater and 17.5 foot extreme tailwater variation
- Minimize sharp-edge shadows that might delay shad migration
- Resting pools within rock ramp fishway
- Slope of channel 3% or below
- Maintain channel stability
- Allow for adjustments in flow and velocity within weir and boulder slots
- Use standard components
- Access road to the left side of the dam

- Water control gates for fishway maintenance and access to left side of the dam
- Limit vertical water velocity components and balance vertical slot velocities
- Allow for trash handling and removal
- Crane access road along the fishway for boulder adjustments and trash handling

B.1.3 Development of the Rock Ramp Layout

A concept layout was developed for the widest practical rock ramp within the available real estate. Figure 3 is a section for the proposed rock ramp looking downstream. It is 75 ft. wide, has a deeper center, and slopes up the inside of the bend. This is a generic layout indicating the three ranges of flow and general dimensions. For clarity it is shown without the rock weirs.

The following calculations are in accordance with industry standards for approximating hydraulic forces, flow velocities and component stability. To accommodate the final project design, physical and/or computational fluid dynamics (CFD) modeling is recommended to verify the assumptions used in this 35% design process.

B.1.3.1 Channel Flow

The rock ramp will be constructed on a minimum 2 foot thick bed of riprap placed over a 6 inch stone bed and filter fabric (Figure 3). Georgia Dept. of Transportation Type 1 (or equal) riprap appears to meet the stability criteria under maximum potential discharge conditions within the rock ramp channel.

Severe Drainage Conditions or Moderate Wave Action (Type 1)*		
Size By Volume	Approximate Weight	Percent Smaller Than
4.2 ft. ³ (0.12 m ³)	700 lbs (320 kg)	100%
1.8 ft. ³ (0.05 m ³)	300 lbs (135 kg)	50%-90%
0.8 ft. ³ (0.02m ³)	125 lbs (55 kg)	20%-65%
* Between 0% and 15% of the Type 1 riprap shall pass a 4 inch (100 MM) square opening sieve.		

The flow through 2 foot deep riprap (within the voids) can be estimated by using an expression developed by Abt (1991). His work at slopes between 1% and 20% indicates that D₁₀ provided the highest correlation to the coefficients developed. The linear regression analysis yielded the expression:

$$V_i = 0.23(gD_{10}S)^{1/2}$$

V_i = average interstitial velocity in feet per second
 g = acceleration due to gravity in ft/sec^2
 D_{10} = 4 inches
 S = gradient expressed in decimal form

$$V_i = 0.23 \left((32.2)(4)(0.03) \right)^{1/2}$$

$$V_i = 0.45 \text{ ft}/\text{sec}.$$

The volume of flow through the riprap changes with water depth:

Q 3.5 ft. deep = 58 cfs
 Q 4.5 ft. deep = 66 cfs
 Q 5.5 ft. deep = 75 cfs

This flow must be considered for determining total velocities through the gate opening.

B.1.3.2 Hydraulic Resistance

To get a perspective of the flow through the rock ramp channel without boulder weirs, the Manning Equation can be used:

$$V = 1.49 R^{2/3} S^{1/2} / n$$

There are a number of ways to determine Manning “n” values depending on the roughness of the channel. Using the table from Alaska Dept. of Highways Hydraulics Design Manual, the n for 1.7 ft. diameter rock would be about 0.038. (Figure 6)

Using the calculated velocity times the flow area, the approximate channel flows would be:

Depth of Flow (ft)	Flow (cfs)	Avg. Velocity (ft/sec)
3.5	1750	11.6
4.5	3000	13.8
5.5	4800	15.8

As a result of the horseshoe configuration, the velocities on the outer edge could be 33% higher than the above average velocities (Figure 7). It would be very difficult to get the target species consistently up the ramp and particularly difficult to achieve passage through the gate structure. Thus, these flows and resulting velocities are unacceptable for fish passage.

B.1.3.3 Boulder Weir Flow

The project design uses boulder weirs at about 25 foot intervals (Figure 4). The maximum head is 115.5 feet minus 98 feet or 17.5 feet. By installing approximately 23 rock weirs, the overall drop per weir system is approximately 9 inches. Between the weirs there are resting pools. Flow adjustment and micro fish passage channels are realized by using the two-tier

boulder weir system illustrated on Figure 4. The channel bottom is lowest in the center (Figures 3 & 5). The weirs are set in an arch pattern to direct the flow to the center. There are 4 and 5 foot boulders spaced with 4 and 5 foot vertical slots between them.

On some rock ramp projects the boulder weir arch is designed with intermediate low sill stone between the boulders to make a self-supporting arch. However, a low sill may impede the passage of sturgeon, so the sill stone has not been considered in this design.

It is difficult to exactly calculate the flow through a weir system but simplified approximation can be achieved. The two weirs forming each step reduce the head loss to about 4.5 inches (0.375 feet) per weir. The average velocity generated by a 0.375 foot head is 4.9 fps ($h = V^2/2g$). In fishway design there are a variety of slot coefficients between 0.75 and 1.04 that are used. Since the boulder shapes are unknown, a coefficient of 1 is proposed. A section (Figure 5) was taken along the center of the upstream primary boulder line. By taking the cross-sectional flow area between each boulder and multiplying it by the average velocity, an approximation of the flow for each flow depth can be computed.

Area 3.5 foot water depth 104 sf x 5 ft/sec = 520 cfs surface flow
Area 4.5 foot water depth 147 sf x 5 ft/sec = 735 cfs surface flow
Area 5.5 foot water depth 216 sf x 5 ft/sec = 1080 cfs surface flow

There may be some concern that the 5 ft/sec velocity would tax some species. This is the benefit of the rock ramp; it provides a range of velocities and depths. Work done by Acharya, (2001) points out that a tiered boulder spacing weir system can provide micro channels that are significantly below average velocities (Figure 4). There is also the vertical velocity profile shown in Figure 2. On the right (shallow) side of the channel, roughness will have a greater effect in reducing velocities on the inside of the channel bend.

B.1.3.4 Velocities of Flow Through Gate Openings

The head gate structure will be installed for maintenance. The proposed system utilizes 8 gates that are 7 feet wide. The gate sills will be flush with the concrete to facilitate sturgeon passage. At low head they flow 3.5 feet deep, average head 4.5 feet deep, and high head 5.5 feet deep. The average velocity through the gates is computed by adding the through flow and the surface flow and dividing by the gate area.

As shown below, the flow velocity at certain flow depths exceeds the criteria set for sturgeon of less than 3 ft/sec. However, Figure 2 indicates that the bottom velocity is approximately 66% of the average river channel velocity. It should be noted that due to the smooth concrete surface (in the head gate area), the flow velocity profile may be more uniform (i.e. less bottom drag than compared to a natural stream). In any event, should field measurements indicate that velocities are too high; an additional boulder weir may be installed either up or down stream of the gate to attain the stipulated velocity criteria.

Flow Depth (ft)	Flow (cfs)	Flow Area (sf)	Flow Velocity (ft/sec)	Velocity Head (ft)
3.5	520 + 58 = 578	196	2.94	1.6
4.5	735 + 66 = 801	252	3.17	1.9
5.5	1080 + 75 = 1155	308	3.75	2.6

B.1.3.5 Rip Rap Design

The stability of the riprap depends on:

- Weight of the rip rap material
- Gradation of the material that offers interlocking
- Depth of water (the deeper the water, the less velocity against rip rap)
- Steepness of the protected area (side slope 1:1, bottom 33:1)
- Ability of the filter blanket to prevent undermining
- Velocity of the water against the rip rap
- Submergence depth of rip rap

The average velocity in pools can be determined by taking the surface flow divided by the cross sectional area:

Flow Depth (ft)	Flow (cfs)	Area (sf)	Channel Velocity (ft/sec)
3.5	520	206	2.5
4.5	735	264	2.7
5.5	1080	362	2.9

Based on the rock ramp layout, controlling design velocity for the riprap is when one of the weirs develops the full 9 inch head. This is about 7 ft/sec average velocity without taking the velocity reduction factor for depth (Figure 7). Based on Table of Equivalent Spherical Diameter of Stone in Feet (Figure 8), the 1:1 side slope would require a 0.75 ft diameter rock to resist displacement. Type 1 riprap has 45% to 80% of the material larger than 1.1 ft diameter. Thus, the side slope riprap at a 1:1 slope is stable if properly placed.

B.1.3.6 Boulder Stability

Condition 1: Two-Tier Boulder System - Stability of Lower Center Boulder

A simplified approach to boulder stability uses the following criteria:

- Static head 0.375 ft. – Straight-line conservative approximation of 23.4 psf
- Velocity head based on 0.375 ft. head drop per weir = 5 ft/sec (possible on downstream boulder)
- Density of stone 165 lb/cf
- Sliding friction coefficient of boulder on rip rap = 0.5

- Drag coefficient for boulder shape based on a two dimensional square cylinder = 2.0 applied 55% up the boulder
- For uplift calculations a straight-line approximation was used with a head differential of 0.375 ft.
- Since the shape and support for each boulder can vary, moments were taken about a point 1 ft upstream of the downstream-most edge for each condition

(See Figure 8 For Loading Diagram)

4 Ft. Boulder Overturning & Sliding

$$C_D = C_P + C_F$$

$$\text{Drag force} = C_D A \rho V^2 / 2 = 2(4' \times 4') 1.96 (5 \text{ ft/sec}^2)^2 / 2 = 784 \text{ lbs}$$

$$\text{Static head} = (23.4 \text{ lbs/sf})(4' \times 4') = 375 \text{ lbs}$$

$$\text{Weight of Stone } 4' \times 4' \times 4' (165 \text{ lbs/cf} - 62.4 \text{ lbs/cf}) = 6566 \text{ lbs}$$

$$\text{Uplift} = 4' \times 4' \times 23.4 = 375 \text{ lbs}$$

$$\text{Overturning Factor of Safety} =$$

$$(6566 \text{ lbs})(1 \text{ ft}) / (784 \text{ lbs} \times 55\% \times 4' + 375 \text{ lbs} \times 1' + 375 \text{ lbs} \times 2') = 2.3$$

$$\text{Sliding Resisting Force with .5 Coefficient of Sliding} =$$

$$\text{Resisting force} = (6566 \text{ lbs} - 375 \text{ lbs}) \times (0.5) = 3095 \text{ lbs}$$

$$\text{Sliding Load} = 784 \text{ lbs} + 375 \text{ lbs} = 1159$$

$$\text{Sliding Factor of Safety} = 3095 / 1159 = 2.7$$

5 Ft. Boulder Overturning & Sliding

$$C_D = C_P + C_F$$

$$\text{Drag force} = C_D A \rho V^2 / 2 = 2(5' \times 5') 1.96 (5 \text{ ft/sec}^2)^2 / 2 = 1225 \text{ lbs}$$

$$\text{Static head} = (23.4 \text{ lbs/sf})(5' \times 5') = 585 \text{ lbs}$$

$$\text{Weight of Stone } 5' \times 5' \times 5' (165 \text{ lbs/cf} - 62.4 \text{ lbs/cf}) = 12825 \text{ lbs}$$

$$\text{Uplift} = 5' \times 5' \times 23.4 = 585 \text{ lbs}$$

$$\text{Overturning Factor of Safety} =$$

$$(12825 \text{ lbs})(1.5 \text{ ft}) / (1225 \text{ lbs} \times 55\% \times 5' + 585 \text{ lbs} \times 2.5' + 585 \text{ lbs} \times 1.5') = 3.4$$

$$\text{Sliding Resisting Force with .5 Coefficient of Sliding} =$$

$$\text{Resisting force} = (12825 \text{ lbs} - 585 \text{ lbs}) \times (0.5) = 6120 \text{ lbs}$$

$$\text{Sliding Load} = 1225 \text{ lbs} + 585 \text{ lbs} = 1810 \text{ lbs}$$

$$\text{Sliding Factor of Safety} = 6120 / 1810 = 3.4$$

Condition 2: Stability of Single-Tier Boulder System

A simplified approach to this condition uses the following criteria:

- Static head of 0.75 ft or 46.8 psf

- Velocity head based on 0.7 ft head drop per weir = 7 ft/sec. between boulders. Figure 7 has an approach velocity of 2.7 ft/sec for a fully submerged stone.
- Density of stone = 165 lbs/cf
- Sliding coefficient of boulder on rip rap = 0.5
- Drag coefficient for boulder shape = 2 (based on a square cylinder) applied 55% up the boulder
- For uplift calculations a straight-line approximation was used with a head differential of 0.75 ft.
- Since the shape and support for each boulder can vary, moments were taken about a point 1 ft upstream of the downstream-most edge for each condition
- Friction drag coefficient = 0.003 (Ahmen 1987 pg 402)

4 Ft. Boulder Overturning & Sliding

$$\text{Friction Drag Force} = C_F A \rho V^2 / 2 = (0.003)(1.96)(7\text{ft/sec}^2)^2 (4' \times 4' \times 2) / 2 = 4.6 \text{ lbs}$$

$$\text{Pressure Drag Force} = C_P A \rho V^2 / 2 = 2 (4' \times 4') 1.96 (2.7\text{ft/sec}^2)^2 / 2 = 229 \text{ lbs}$$

$$\text{Static head} = (46.8 \text{ lbs/sf})(4' \times 4') = 749 \text{ lbs}$$

$$\text{Weight of Stone } 4' \times 4' \times 4' (165\text{lbs/cf}-62.4 \text{ lbs/cf}) = 6566 \text{ lbs}$$

$$\text{Uplift} = 4' \times 4' \times 46.8 = 749 \text{ lbs}$$

$$\text{Overturning Factor of Safety} =$$

$$(6566 \text{ lbs})(1\text{ft}) / (229 \text{ lbs} \times 55\% \times 4' + 749 \text{ lbs} \times 2' + 749 \text{ lbs} \times 1' + 4.6 \text{ lbs} \times 55\% \times 4) = 2.4$$

$$\text{Sliding Resisting Force with .5 Coefficient of Sliding} =$$

$$\text{Resisting force} = (6566\text{lbs} - 749\text{lbs}) \times (0.5) = 2909 \text{ lbs}$$

$$\text{Sliding Load} = 749 \text{ lbs} + 4.6 \text{ lbs} + 229 \text{ lbs} = 983 \text{ lbs}$$

$$\text{Sliding Factor of Safety} = 2909/983 = 3.0$$

5 Ft. Boulder Overturning & Sliding

$$\text{Friction Drag Force} = C_F A \rho V^2 / 2 = (0.0035) (5' \times 5' \times 2) (1.96)(7\text{ft/sec}^2)^2 / 2 = 8.4 \text{ lbs}$$

$$\text{Pressure Drag Force} = C_P A \rho V^2 / 2 = 2 (5' \times 5') 1.96 (2.7\text{ft/sec}^2)^2 / 2 = 357 \text{ lbs}$$

$$\text{Static head} = (46.8 \text{ lbs/sf})(5' \times 5') = 1170 \text{ lbs}$$

$$\text{Weight of Stone } 5' \times 5' \times 5' (165\text{lbs/cf}-62.4 \text{ lbs/cf}) = 12825 \text{ lbs}$$

$$\text{Uplift} = 5' \times 5' \times 46.8 = 1170 \text{ lbs}$$

$$\text{Overturning Factor of Safety} =$$

$$(12825 \text{ lbs})(1.5\text{ft}) / (357 \text{ lbs} \times 55\% \times 5' + 1170 \text{ lbs} \times 2.5' + 1170 \text{ lbs} \times 1.5' + 8.4 \text{ lbs} \times 55\% \times 5') = 3.4$$

$$\text{Sliding Resisting Force with .5 Coefficient of Sliding} =$$

$$\text{Resisting force} = (12825\text{bs} - 1170\text{lbs}) \times (0.5) = 5828 \text{ lbs}$$

$$\text{Sliding Load} = 1170 \text{ lbs} + 8.4 \text{ lbs} + 357 \text{ lbs} = 1535 \text{ lbs}$$

$$\text{Sliding Factor of Safety} = 5828/1535 = 3.8$$

B.1.3.7 Entrance and Exit Considerations

Fishway Entrance

The location of the entrance is critical to good fish passage. According to the agencies, the following general observations with respect to fish movement have been noted:

- Fish move up the river below the navigation lock along the right side (looking downstream) of the river.
- Fish move across the spillway from right to left and congregate in the area of Gate 5 (closest to the South Carolina side of the river).

As a result, it was agreed upon that for a horseshoe rock ramp configuration, the upstream entrance below Gate 5, should be located as close to the spillway as possible and in an area where turbulence from the gate discharge does not distract from its effectiveness.

Fishway Exit

It is important that the upstream exit, above Gate 5, be located in an area that has a water velocity equal to, or greater than the threshold velocity of the fish leaving the exit. The threshold velocity leads the fish for orientation away from the Gate 5 area, and it can be as low as 1 cm/sec (Clay 1995). However, the water velocity must also be less than the critical velocity (maximum sustained swimming speed of the target fish) when the flow downstream is great enough to sweep the fish over the dam.

B.1.4 Resulting Configuration

The resulting configuration of the fish bypass canal is shown on drawings titled Savannah 3 through Savannah 6 within Appendix A. The canal is approximately 650 feet in length, installed on a grade of 3 percent and utilizes a modified trapezoidal cross section measuring 75 feet wide at the base with 1H:1V side slopes.

To best achieve the desired flow conditions within the canal, rock weirs are placed on a radial pattern located approximately 25 feet on centers. On the outside section of the canal 5 ft. boulders are located on approximately 5 ft. spacing. On the inside section of the canal, 4 ft. boulders are spaced on 4 ft. centers with intermediate placements between the radial weirs to create slower flow velocities and resting pools.

The entire canal is protected from erosion by a 2 ft. layer of riprap placed over bedding stone and filter fabric. The downstream entrance/exit invert elevation is 93.0 and is located as close to Gate 5 area as possible. There will be a transition area between elevation 93.0 and elevation 85.0 along the downstream bank that will receive an application of rip rap to create a more smooth transition from the natural river bottom to the man-made canal. The upstream exit/entrance invert elevation is 110.0 and is also strategically located to enhance the movement of both upstream and downstream fish movement. Similar to that downstream,

riprap will extend from the invert elevation 110.0 to approximately elevation 95 to provide a smooth transition from the natural river bed to the canal entrance.

A headwater control structure will be located at the upstream entrance to the canal and is addressed in further detail in Section IV.B.2 of this report.

To reduce the accumulation of debris just upstream of the headwater control structure, it is recommended that a floating trash boom be installed.

B.2 Headwater Control Structure

B.2.1 Objectives

The primary objectives of the Headwater Control Structure are as follows:

- Provide a means to isolate the canal from the Savannah River in the event that maintenance is required along the fish bypass channel;
- Provide sufficient opening area and flow bypass characteristics to allow all target species the ability to move through the bypass system without velocity barriers;
- Provide rolling stock access to the left abutment of the New Savannah Bluff Lock & Dam Structure if required;
- To provide a cost effective and passive system with minimal future maintenance; and,
- Provide access and structures to accommodate future fish monitoring activities, as required by the resource agencies.

B.2.2 General Design Criteria

The headwater control structure will be designed in accordance with the following:

Operating Design Conditions:

Condition A - Normal Operating

Headwater Elevation – Between Elevation 115.5 and 113.5

All Gates – Open Position

Condition B – Normal Canal Maintenance Condition

Headwater Elevation – Between Elevation 115.5 and 113.5

All Gates – Closed Position

Condition C – Extreme Canal Maintenance Condition

Headwater Elevation – Elevation 118.72 (Max, Recorded Elev. Post 1/11/92)

All Gates – Closed Position

Other Design Assumptions:

- Any stabilizing effects and/or contributions from the sheet pile wall is neglected (Conservative)
- The structure shall be designed for the full hydrostatic head and associated uplift (Conservative)
- The structure will be designed on a per foot basis without stability contributions from the structure / abutment interface (Conservative)

Minimum Factors of Safety:

Listed below are the minimal factors of safety for the various operating conditions:

Condition	Overturning	Sliding
A – Normal Operating	1.5	1.5
B – Normal Canal Maintenance	1.5	1.5
C – Extreme Canal Maintenance	1.2	1.2

B.2.3 Methodology & Analysis

Conventional calculations were performed for both the structural overturning and sliding. A copy of the calculation is provided in Appendix H.1. Listed below are the results of this analysis.

Condition	Overturning	Sliding
A – Normal Operating	>> 2.0	>> 2.0
B – Normal Canal Maintenance	1.81	2.31
C – Extreme Canal Maintenance	1.33	1.33

Note: Even though the factor of safety for overturning is 1.33 for the condition of extreme canal maintenance, the analysis is considered very conservative due to the conservation nature of the calculation (i.e. not all of the resisting loads were utilized). Had all of the contributing resisting forces been included, factors of safety for the extreme conditions greater than 1.5 would be expected. Furthermore, the gates will only be lowered and the canal isolated for routine maintenance. Canal maintenance during extreme flooding conditions is considered to be an unreasonable design condition.

Due to the need for mass concrete, the level of concrete reinforcement required is expected to be controlled by ρ minimum (crack control only).

B.2.4 Resulting Configuration

Listed below is a brief description of the headwater retaining structure. Additional details of the structure are provided on Drawings provided in Appendix A.

The reinforced concrete headwater control structure will be located at the upstream entrance to the canal approximately 20 feet from the river edge. The structure will span the fish bypass canal measuring approximately 105 feet wide. The top of the structure will be at elevation 120 and the invert elevation established at 108.0. The crest of the structure will measure 8 feet wide and provide approximately 5 feet of unobstructed authorized access. Hand rails along each side of the structure will be provided along with removable grating covering the stop long slots.

The structure will be constructed with 8 gate openings measuring 7 feet wide and 8 feet tall. Each gate opening will be installed with slide gates fabricated of non-corrosive materials. Each gate will be provided with manual operators. In the event it becomes necessary to isolate a gate, one set of stop logs will be provided. The threshold for each gate will be flush with the structure invert and provide smooth passage for migrating fish. For additional details regarding the proposed gate system, please refer to Appendix I.

In order to control seepage both under and around the structure, a sheet pile cut-off wall is proposed. This cut-off wall would be installed to a minimum elevation of 92.0 and extend from the existing dam wing wall through the structure, terminating approximately 30 feet beyond the structure in the easterly (upstream) direction.

All metallic surfaces would be properly coated to prohibit corrosion and minimize long-term maintenance.

The USACE has proposed tapping into an electrical source on the existing dam structure for future electrical needs if required.

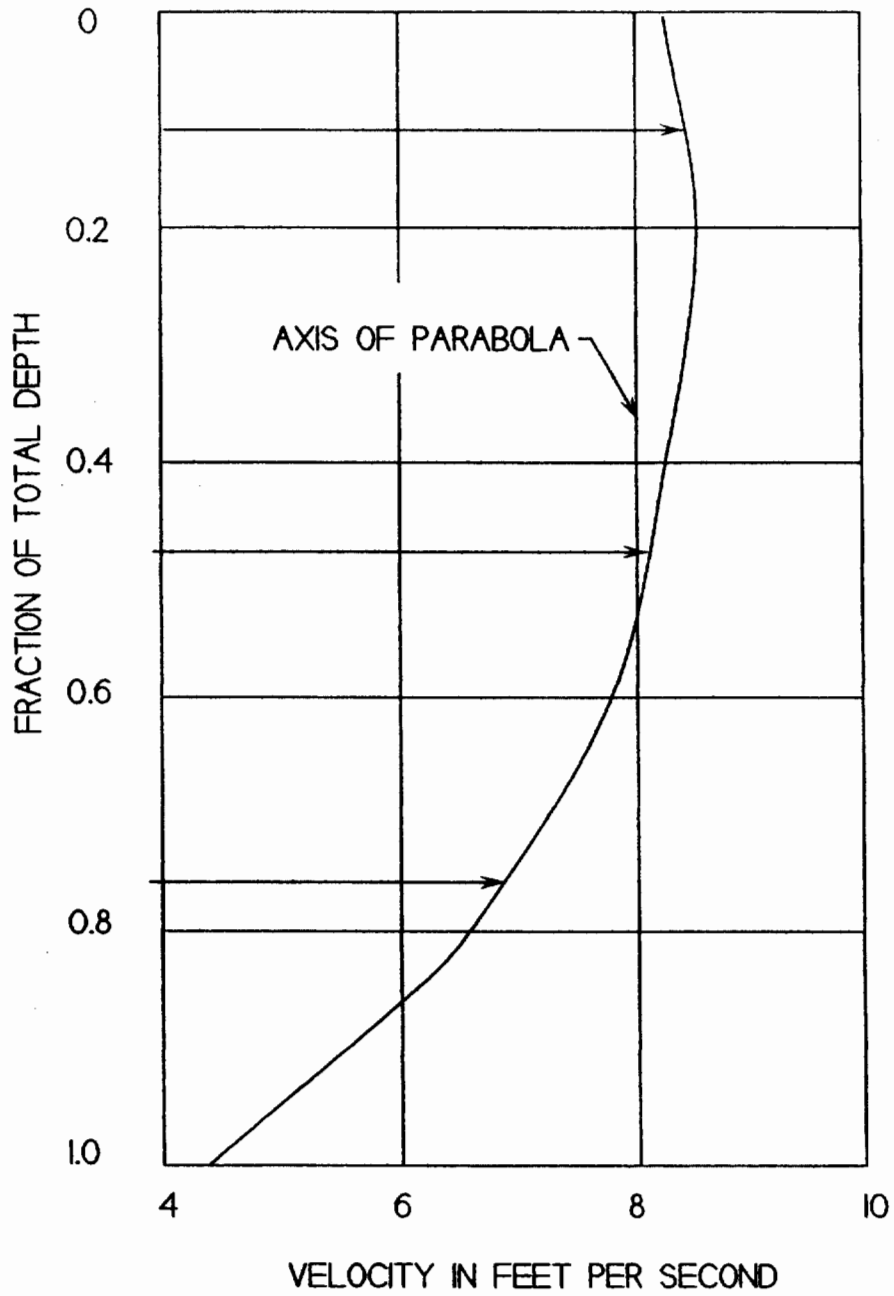

A TYPICAL VERTICAL VELOCITY PROFILE IN A STREAM
 ADAPTED FROM LINSLEY, 1958

FIGURE 2

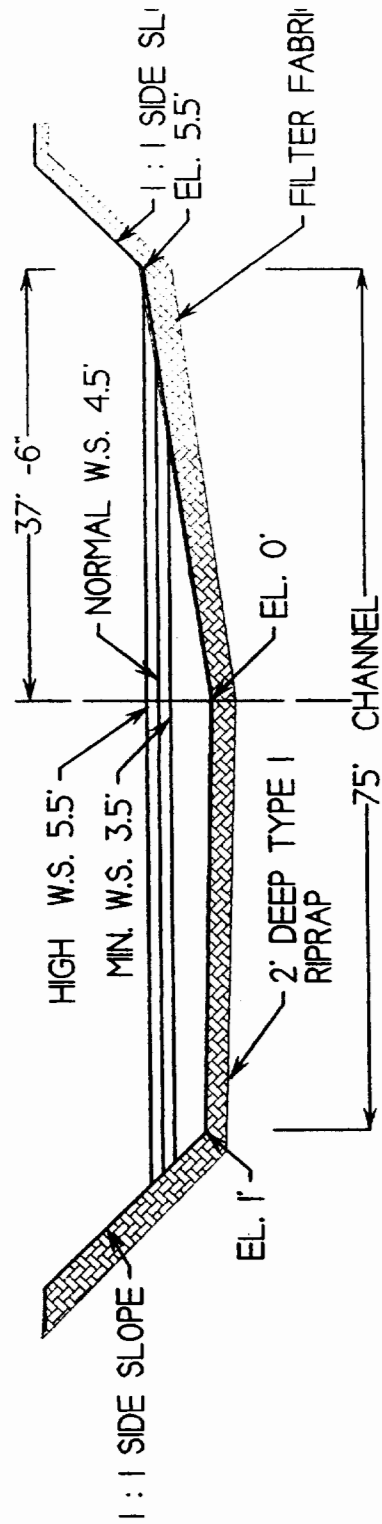

TYPICAL CHANNEL SECTION
 ACROSS THE FLOW (WITHOUT BOULDERS)
 LOOKING DOWNSTREAM

FIGURE 3

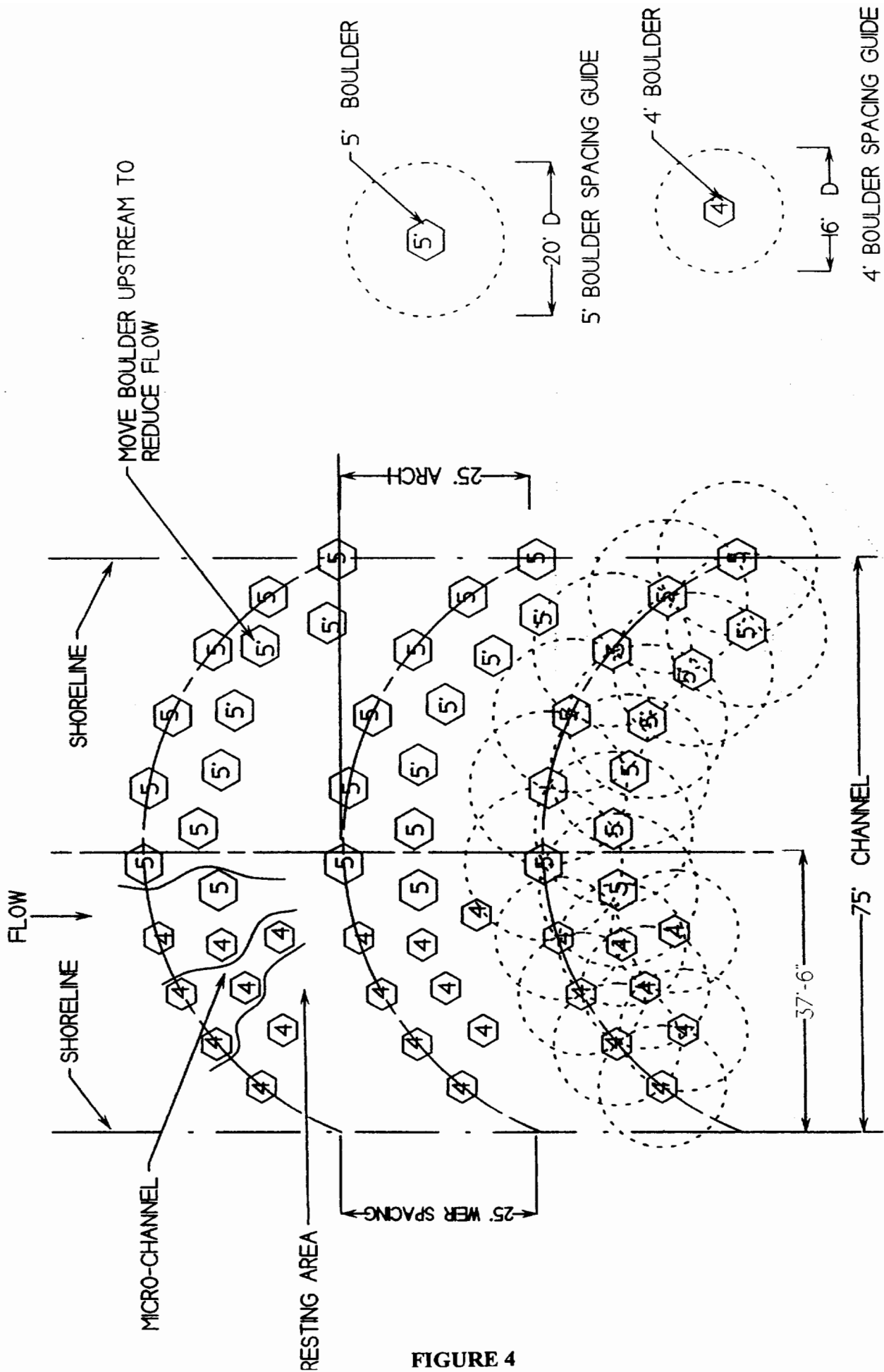
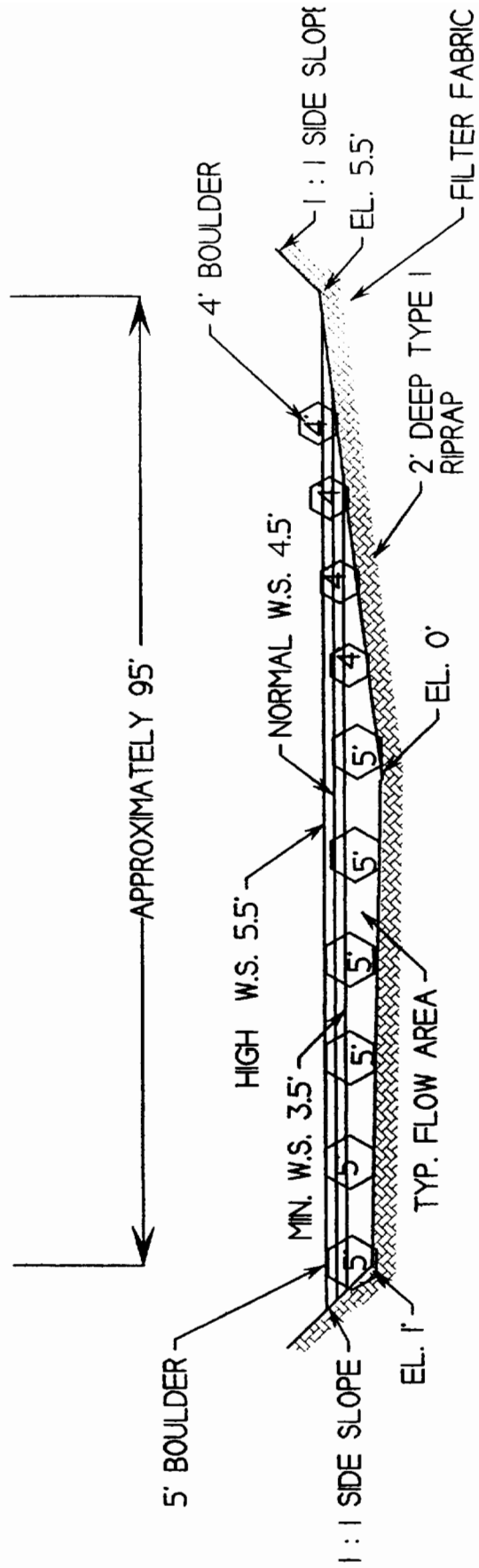

FIGURE 4

PLAN VIEW BOULDER LAYOUT FOR THREE
ROCK RAMP WEIRS



TYPICAL SECTION ALONG THE UPSTREAM BOULDER WEIR
LOOKING DOWNSTREAM

FIGURE 5

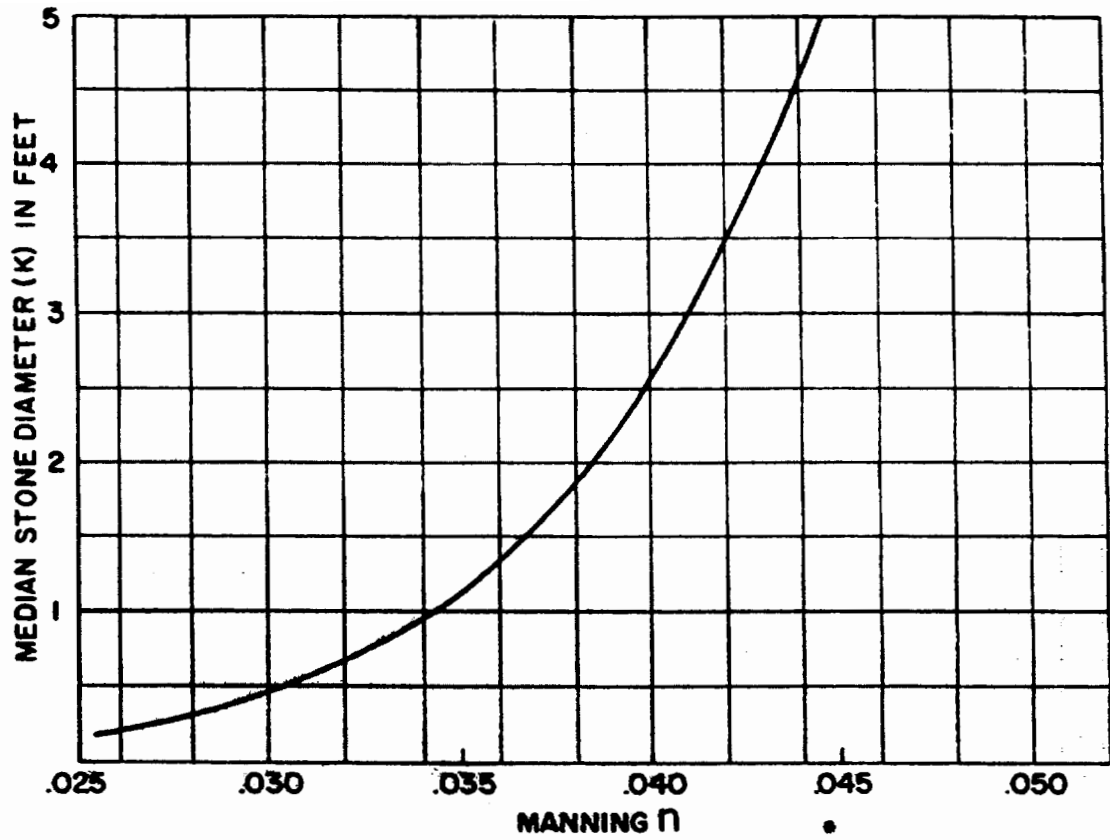

Relation of Manning n to size of stone

FIGURE 6

Adapted from Hydraulics Manual, State of Alaska, Department of Highways

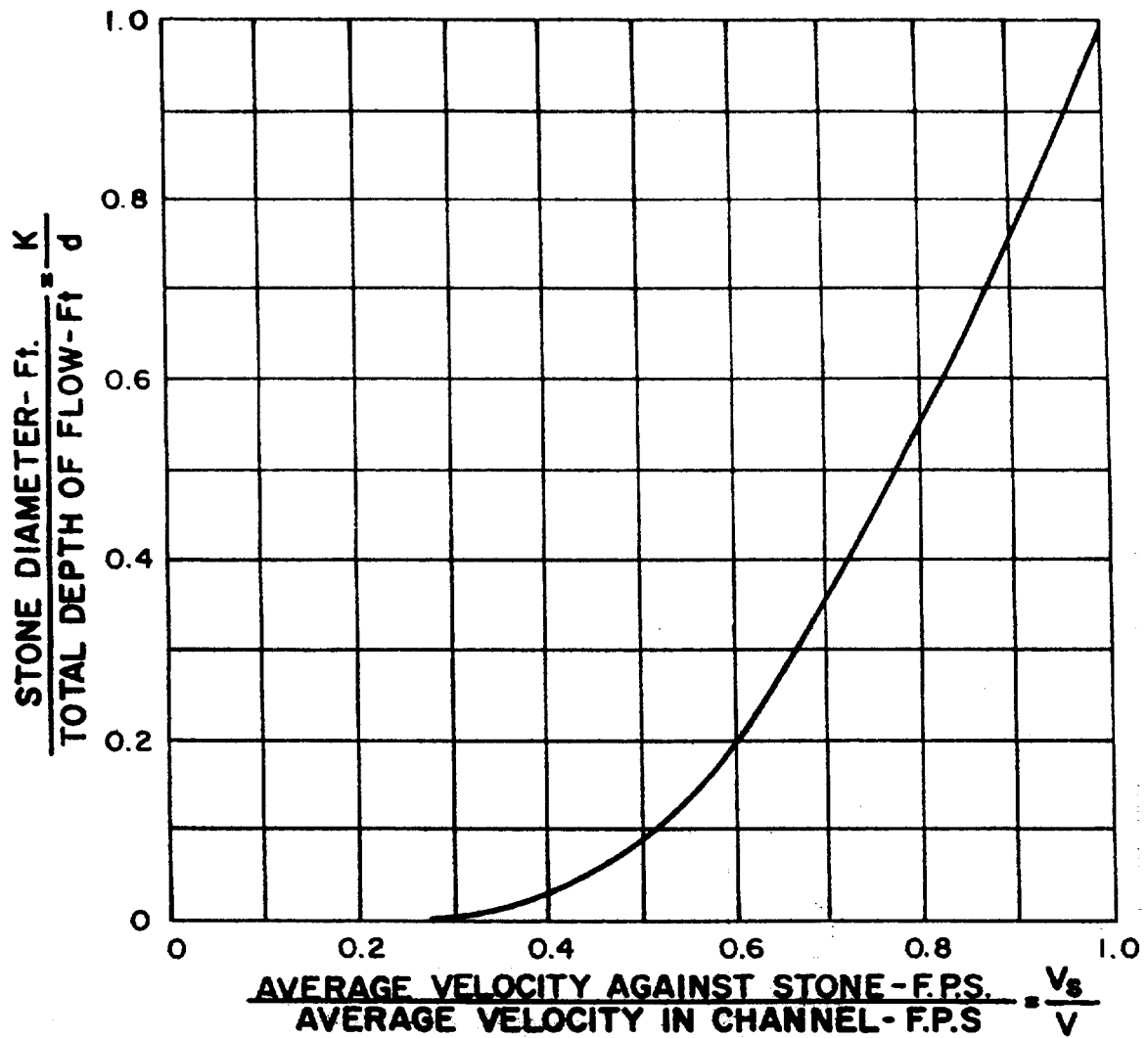

**AVERAGE VELOCITY
AGAINST STONE
ON CHANNEL BOTTOM**

Use Velocity in Channel = $\frac{4}{3}$ X (Average Velocity in Channel)
for curved sections.

FIGURE 7

Adapted from Hydraulics Manual, State of Alaska, Department of Highways

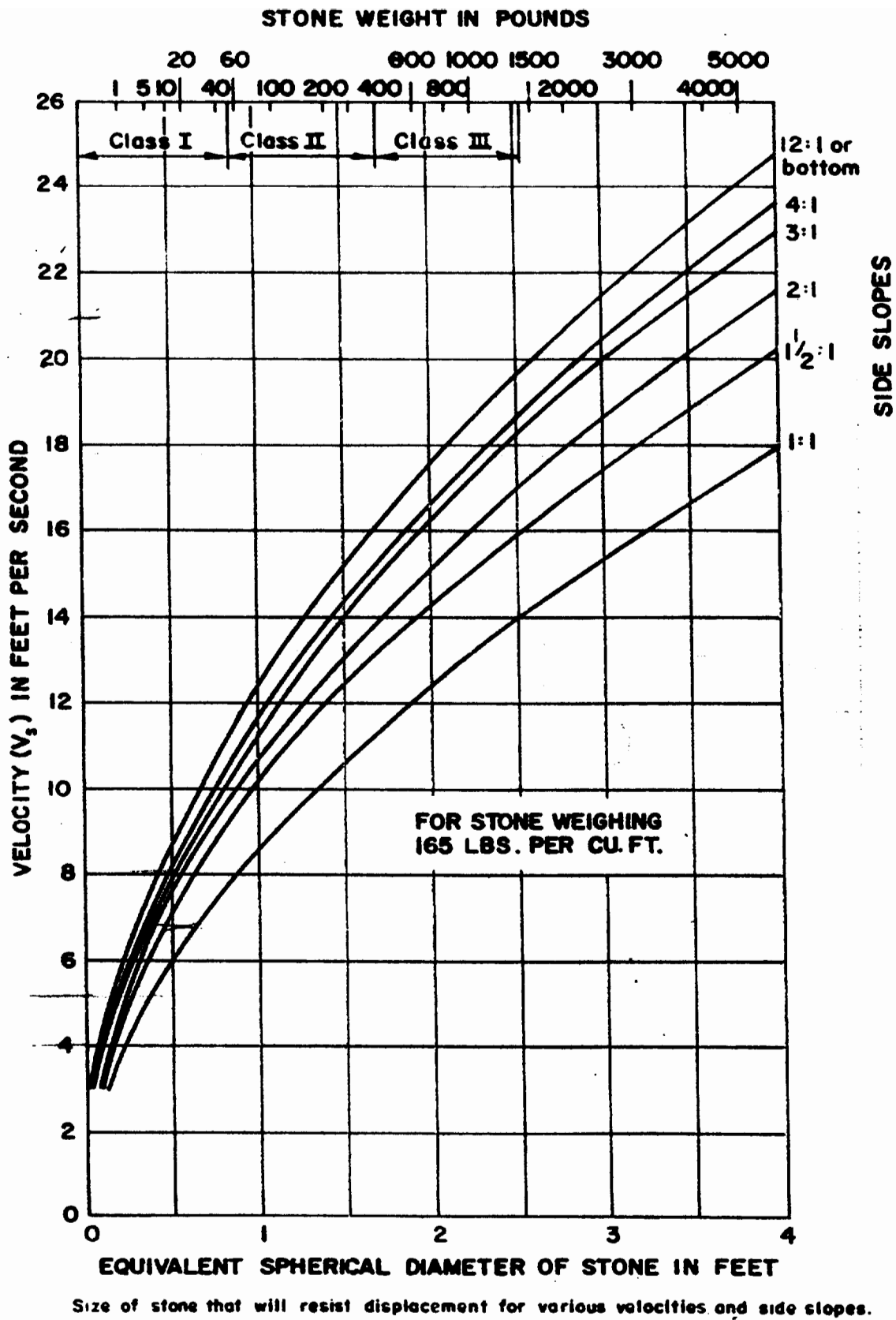
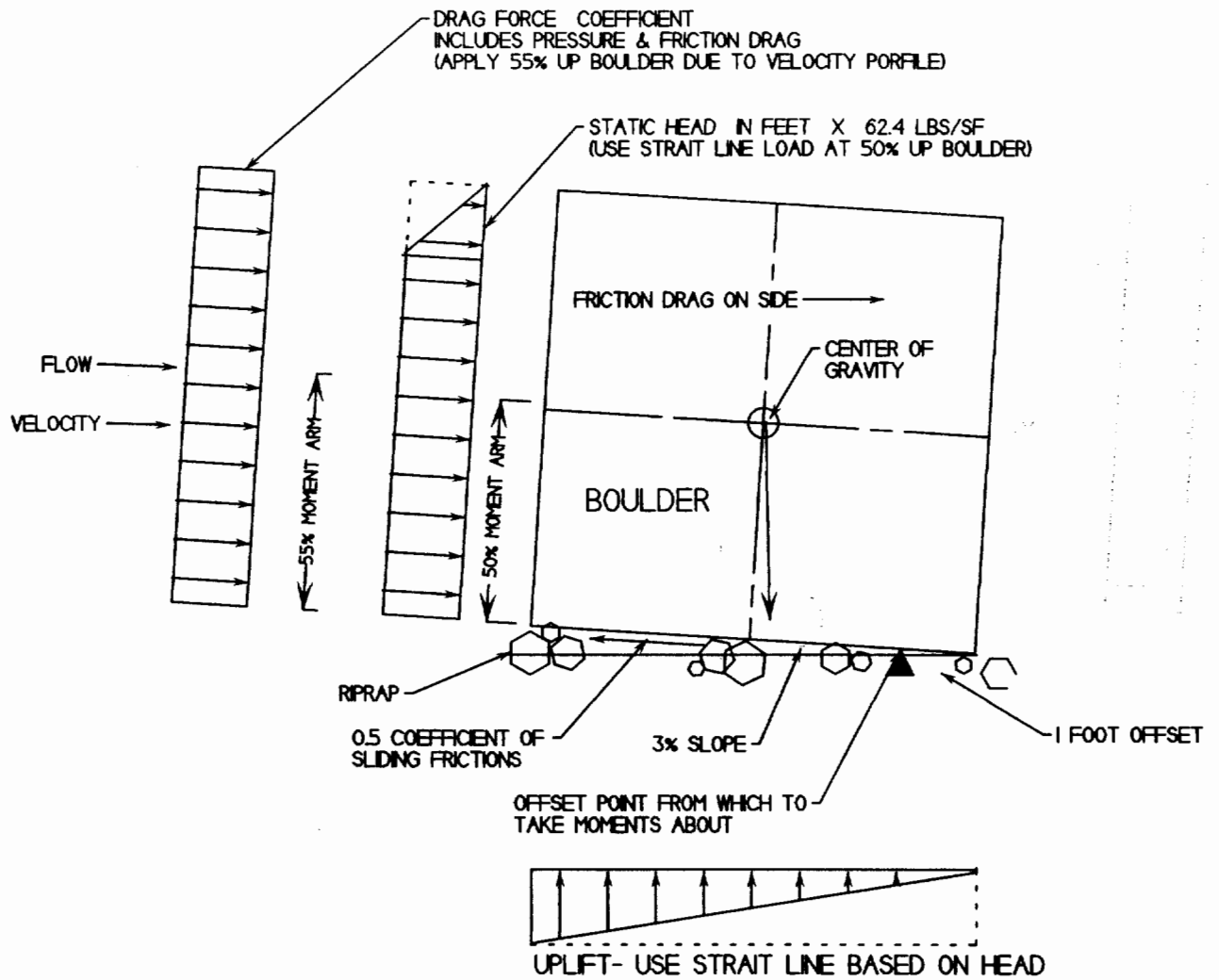

FIGURE 8

Adapted from Hydraulics Manual, State of Alaska, Department of Highways



TYPICAL BOULDER LOADING SKETCH

FIGURE 9

B.3 On-Site Access

B.3.1 Objectives

It has been requested by the Corps of Engineers that access across the rock ramp fishway structure be provided as follows:

- Authorized Personnel Access – Authorized access (foot traffic) across the headwater control structure to facilitate routine maintenance, fish monitoring, etc., during periods of normal operation. It is assumed that the facility will not permit open and unobstructed access across the facility.
- Authorized Vehicular Access – In the event it becomes necessary to access the left abutment of the dam via rolling stock for required maintenance or repairs.

B.3.2 General Design Criteria

Personnel Access

- Allocate sufficient space for safe and unobstructed access
- Provide handrails across structure

Vehicular Access

- Provide “in the dry” access across canal when headwater structure gates are in the closed position
- The access road shall be constructed with a maximum grade of 15% and shall provide for a minimum turning radius of 50 feet.
- The submerged access road shall be stable and erosion resistant under design operating conditions.
- The design shall pose no detriment to overall fish passage objectives

B.3.3 Methodology & Analysis

No structural analysis required, slab thickness determined by engineering judgment.

B.3.4 Resulting Configuration

Personnel Access

An 8 foot wide horizontal platform provides approximately 5 feet of unobstructed personnel access along the upstream crest of the headwater control structure. For safety measures the structure will be installed with handrails and removable grating to cover the stop log openings. The handrails and grating are assumed to be fabricated of carbon steel and properly coated for corrosion resistance.

Vehicular Access

Vehicular access ramps are provided along both the canal side slopes just downstream of the water control structure. The ramps are assumed to be 15 feet wide and constructed on a grade not to exceed 15 percent. The side slopes are assumed to be protected with riprap and the roadway covered with an 8 inch concrete slab.

B.4 Off-Site Access

B.4.1 Objectives

It has been requested by the Corps of Engineers that off-site access be provided to the structure as follows:

- Authorized Vehicular Access - Temporary easement during construction and long term easement to facilitate operations and maintenance.
- Barge Access - Temporary access for material delivery

B.4.2 Resulting Configuration

To be determined following the receipt of information from the U.S Corps of Engineers.

B.5 Security

B.5.1 Objectives

Provide adequate security to the site permitting only authorized personnel and vehicular access.

B.5.2 Resulting Configuration

The subject site containing the fish bypass system will be surrounded on the east, south and west by an 8 feet tall chain link fence topped with three strands of barbed wire. There will be at least one location installed with a manually operated gate measuring approximately 16 feet in width to accommodate authorized vehicular access. There will also be at least one personnel type gate access.

There are no plans for exterior lighting and/or remote monitoring.

B.6 Construction Methodology

The subject fish bypass system will be constructed along the abutment of the Savannah River. To facilitate constructing much of the facility in the dry, both upstream and downstream earthen cofferdams will be utilized. Each earthen cofferdam will be constructed with 1.5 to 1 slopes and located in such a manner as to minimize the placement of fill

material into the river and yet provide the maximum space with which to construct both the canal and the headwater control structure. After completion of the canal and headwater control structure, the cofferdams will be removed with conventional earthmoving equipment and the cofferdam footprints will be lined with riprap.

The entire canal will be excavated utilizing conventional earth moving equipment. The subsurface conditions consist of silt and sandy materials and no rock should be encountered. It is desirable that the fish bypass canal be constructed in a very controlled manner to salvage as many of the existing trees as possible. Should it not be possible to salvage trees as originally thought, it is recommended that a planting program be initiated to install additional trees (i.e. river birch, willows, etc.) at various locations along the bypass canal perimeter.

During construction, there is a high degree of certainty that the excavation will require unwatering resulting from seepage from the adjacent river. In addition it may be necessary to place geotextile filter fabric and riprap along both the upstream and downstream slopes of the cofferdam to protect against the movement of fines and surface erosion.

All riprap and boulders are assumed to be delivered to the site via barge. Concrete and other materials are assumed to be delivered via overland access.

All material disposal is assumed to be off-site unless other arrangements are made and approved by all parties.

B.7 Testing, Commissioning and Evaluation Criteria

B.7.1 Objectives

It is expected that there will be two phases to the testing and evaluation program. Phase 1 will be to measure the physical flow and representative point velocities in the rock ramp channel over the three-target headwater ranges. The objective of Phase 1 will be to determine if the fishway hydraulics meet recognized hydraulic criteria to pass the target fish species and are within the design range.

Phase 2 testing will address the biological effectiveness of the fishway to confirm target species are passing through the fishway. Phase 2 testing is not addressed in this report.

B.7.2 Methodology

The total flow data (rock ramp channel discharge) for Phase 1 may be gathered with an acoustic Doppler current meter that can take transects in the area of the gate structure at the three target headwater elevations. If an acoustic Doppler unit is not available, individual point measurements of depth, velocity and cross sectional area in the gates can be used to establish the total flow through the channel.

Also, the flows at the boulder weirs should be observed for any gross area that may inhibit fish passage with excessive velocity or turbulence. If there are apparent problems, individual

boulders can be moved to adjust flows. For a set of two boulder weirs, taking three dimensional point velocities around the boulders and within micro channels should make a more detailed velocity analysis. Temporary access from which to perform these measurements is assumed to be provided via wood planking secured to the tops of the boulders within the canal.

B.8 Operations and Maintenance

B.8.1 Objectives

The general consensus is that a rock ramp fishway will take less maintenance than a traditional technical fishway. The rock ramp fishway is designed to be self-regulating over the normal operation headwater range. Headwater elevation in the Savannah River is controlled by adjusting the three center dam gates from a remote location, and is coordinated with water releases from upstream projects. The velocities within the rock ramp fishway should be high enough to prevent any major bed load sediment buildup within the rock ramp channel.

B.8.2 Methodology

Minor adjustments to boulder locations may be required during normal operation. To facilitate these adjustments, a mobile crane could be used. Stainless steel lifting bolts, which are anchored permanently with adhesive, or holes, which are typically drilled in large rocks for quarry work, on the boulders would allow rotating or lifting with the mobile crane. This reduces the equipment size required to move the boulders and the load to be lifted. A lifting chain/dogs can weigh less than 100 lbs. An orange peel, to move the same weight rock, could weigh 5,000 lbs.

It is recommended that a floating boom be installed just upstream of the headwater control structure in such a manner to deflect floating debris toward the direction of Gate No. 5. In any event, it may become necessary to periodically removal some debris accumulation from in front of the floating devise or either material that may possibly bypass the boom and accumulate just upstream of the headwater control structure. It is expected that small items will go right through the rock ramp fishway.

Historically, the gates on the project have been manipulated to draw large trash from the side of the river to be sluiced. If this procedure does not continue to work, a mobile crane with a grapple or a stationary hoist to draw trash from the fishway to the dam gate structure may be needed.

V Construction Schedule

All project schedules, including project and construction, are to be completed by the U.S. Army Corps of Engineers or as otherwise directed by the U.S. Army Corps of Engineers.

VI Cost Estimate

A. Material Quantity Estimate

Listed below is a rough estimate of major quantities necessary to construct the NSBL&D Fish Bypass System:

Item	Description	Units	Quantity
A	Site Prep & Temporary Works		
	Access Roads	LM	TBD
	Barge Unloading Facility	LS	1
	Temporary Cofferdams		
	Filter Fabric	SY	2100
	Riprap	CY	710
	Earthwork	CY	35000
	Utilities	LS	1
	Construction Power	LS	1
	Water Control	LS	1
	Site Laydown Area	LS	1
	Temporary Fencing	LF	1400
	Erosion Control	LS	1
B	Civil Works		
B.1	Earth Work & Drainage		
	Clearing & Grubbing	Acre	4
	Earthwork		
	Excavation	CY	53000
	Disposal	CY	58000
	Filter Fabric	See	11000
	Riprap	CY	7400
	Boulders	EA	500
	Rough Grading	Acre	4
	Fine Grading	Acre	4
	Canal Access Concrete Paving	CY	56
B.2	Headwater Structure		
	Sheet Piling	SY	5250
	Concrete	CY	450
	Reinforcing	Ton	15
	Miscellaneous Steel		
	Handrail	LF	230
	Grating	Ton	1
	Miscellaneous Steel Embeds	Ton	1
	Slide Gates w/Operators	EA	8
	Stop Logs	EA	1
B.3	General		
	Landscaping	LS	1
	Fencing	LF	1400
	Access	LF	TBD
C	Electrical Works	LS	TBD
D	Mechanical Works	NA	NA

B. Other Issues That Could Effect Installation Costs

Listed below are several items that could affect the completed installed cost of the rock ramp fish bypass system:

B.1 Surgical Excavation

Over the course of studies, there has been some discussion regarding the need to save as many trees as possible on the construction site. Due to limited space along the left abutment and the need for staging and lay down area, it may be difficult to save a large number of the existing trees. However, for the purpose of this report, it is assumed that small earth moving equipment will be utilized.

B.2 Testing & Commissioning

Due to the nature of rock ramp fish bypass systems, field adjustments to weirs and boulders will be necessary during testing and commissioning to achieve the desired performance. As a result, additional money should be allocated within the budget for both a standby crane with sufficient capacity and boom. Field engineering (Fish Bypass Specialist) support will be required during commissioning to measure velocities within the rock weirs and direct boulder adjustments.

B.3 Off-Site Disposal of Materials

Due to space limitations, it was decided to assume that all excavated materials would be disposed of off-site.

B.4 Access Limitations

At the time of this engineering study, the availability of over land site access was unclear. As a result, it should be assumed that all material deliveries and disposals be accomplished via barge.

C. Cost Estimate

The project cost estimate is to be completed by others under the direction of the U.S. Army Corps of Engineers.

VII Study Conclusions and Recommendations

Conclusions

The NSBL&D Project has been given a Congressional mandate to continue operation as a navigation lock, allow transfer of ownership to the City of North Augusta and Aiken County, South Carolina, and provide both upstream and downstream fish passage for a diversity of fish species, including rare and endangered species. Fish passage options are limited by the available real estate and by the restriction on structural interaction with the lock. However, the low head at this site, combined with the consistent headwater, provide an opportunity to construct a self-regulating, cost effective horseshoe-shaped rock ramp fishway. Benefits of the horseshoe rock ramp fishway are the nature-like hydraulic features for fish passage, lower capital costs and lower operating costs. An additional benefit of the rock ramp fishway is that it creates new rocky shoal habitat that some species of fish may find attractive for spawning or residence within the structure. Also, the flow control structure at the head of the rock ramp fishway can be used to enumerate and manage the fish species that migrate past this point in the Savannah River drainage.

The project is fortunate that there have been ongoing fish behavior studies of many of the target species at the NSBL&D site. The fishway entrance is the most critical aspect of effective fish passage design. The studies provided confirmation that the proposed location of the upstream passage entrance is where migratory fish congregate. The resource agencies have stated that there is a diverse species assemblage that needs both upstream and downstream passage at the site. The rock ramp fishway provides diverse hydraulic conditions in pool depth and velocity to accommodate the swimming abilities of target species. The proposed system allows flexibility in adjustment of boulder weirs if ongoing studies of fish migration indicate modifications are necessary.

There does not appear to be any technical or economic (within congressional mandated funding limits) reasons that the project could not be effectively completed. Efforts should be made to assure funding is available to complete the design and construct the project.

Additional Recommendations

There should be a continued dialog between those conducting the fish migration studies at the project site, those preparing the final project design and the resource agencies. The interpretation of the fish movements must be consistent with the proposed designs.

There has been some discussion regarding additional modeling efforts, including a Computational Fluid Dynamics (CFD) computer modeling and the need to build a full-scale physical hydraulic model. Listed below are our thoughts on each, including advantages, limitations, outcome and recommendations:

Computational Fluid Dynamics Modeling

Advantages – CFD Modeling is an excellent cost effective tool for determining head loss and flow characteristics around boulders.

Disadvantages (Limitations) – The drag coefficients are not easily modeled by the CFD method.

Recommendations – CFD Modeling should be performed during final project design.

Physical Modeling

Advantages – A physical model could be constructed to various levels of detail, including the modeling of only individual boulders (of various sizes and shapes) to confirm drag coefficients, to a full-scale prototype to model the entire operations, including flows combinations through the bypass system and adjacent gate no. 5.

Disadvantages (Limitations) – Depending on the modeling effort (i.e. individual boulders vs. full-scale prototype modeling) the costs could escalate from around \$20,000 to over \$100,000.

Recommendations – At this point, we recommend as minimum that boulders of various sizes and shapes be physically modeled to confirm boundary conditions utilized within the CFD modeling as well as the boulder stability calculations.

Technical References

- Abt, S.R., J.F. Ruff, R.J. Wittler. 1991. Estimating Flow through riprap. ASCE Journal of Hydraulic Engineering 117:670-675, 1991.
- Beamish, F.W.H., R.S. McKinley, D.A. Scruton, C. Katopodis. 1996. Relating swimming performance of lake sturgeon, *Acipenser fulvescens*, to fishway design. Can. J. Fish. Aquat. Sci. 54:1361-1366, 1997.
- Bell, Milo. 1986. Fisheries Handbook of Engineering Requirements and Biological Criteria. 2nd Edition. Corps of Engineers, Portland, Oregon.
- Brater, E. F., H. W. King. 1976. Handbook of hydraulics for the solution of hydraulic engineering problems. 6th Edition. McGraw-Hill, Inc., NY.
- Clay, Charles H. 1995. Design of fishways and other fish facilities. 2nd Edition. CRC Press, Boca Raton, Florida.
- Framatome ANP DE&S (FANP DE&S). 2002. New Savannah Bluff Lock & Dam Project, Savannah River Georgia and South Carolina, Fish Passage Report. Prepared for U. S. Army Corps of Engineers, Mobile AL, August 2002.
- Haro, A., B. Kynard. 1997. Video evaluation of passage efficiency of American shad and sea lamprey in a modified ice harbor fishway. North American Journal of Fisheries Management 17:981-987, 1997.
- Kells, J.A., M. Acharya, C. Katopodis. 2000. Design of nature-like fishways for small dam projects. Proceedings, 3rd Annual Conference, Canadian Dam Association.
- Kynard, B. 1998. Twenty-two years of passing shortnose sturgeon in fish lifts on the Connecticut River: What has been learned?. Fish Migration and Fish Bypasses. Blackwell Science Ltd., Malden, MA.
- Linsley, R.K., M. Kohler, J.L.H. Paulhus. Hydrology for Engineers. McGraw-Hill Book Company, Inc. 1958.
- Maynard, S.T. 1991. Flow resistance of riprap. ACSE Journal of Hydraulic Engineering 117:687-695, 1991.
- Mefford, B. 2002. Designing combination structures, notes. Engineering Innovative Fish Passage: Dam Removal and Nature-like Fishways. NH Dept of Environmental Services, Waterville Valley, NH.
- Monk, B., D. Weaver, C. Thompson, F. Ossiander. 1989. Effects of flow and weir design on the passage behavior of American shad and salmonids in an experimental fish ladder. North American Journal of Fisheries Management 9:60-67, 1989.

Moser, M., A. M. Darazsdi, J. R. Hall. 1999. Improving passage efficiency of adult American shad at low-elevation dams with navigation locks. *North American Journal of Fisheries Management* 20:376-385, 2000.

Painter, R.E., L. H. Wixom. Striped bass fishway and swimming endurance tests. Sixth Annual Report, California Department of Water Resources.

Parasiewicz, P. J. Eberstaller, S. Weiss, S. Schmutz. 1998. Conceptual guidelines for nature-like bypass channels. *Fish Migration and Fish Bypasses*. Blackwell Science Ltd., Malden, MA.

Scheidegger, K. 2002. Fish gotta swim. *Wisconsin Natural Resources Magazine*. Wisconsin Department of Natural Resources.

State of Alaska, *Hydraulics Manual*, State of Alaska Department of Highways.

Washington Sea Grant Program. Fishway use by white sturgeon on the Columbia River. Washington Sea Grant Program, Seattle, WA.

Weaver, C., C.S. Thompson, E. Slatick. 1969. Effect of weir configuration on fish passage. Fourth Progress Report on Fisheries Engineering Research Program 1966-1972. US Army Corps of Engineers. May 1976.

Wittler, R.J. 1996. Features of a chevron weir rock ramp. North American Water and Environment Congress. American Society of Civil Engineers.

Appendices

Appendix A - Drawings

NOTE:
 ZERO MILE IS SAVANNAH HARBOR STATION 0+000
 (VICINITY FT. PULASKI) MOUTH OF SAVANNAH RIVER.

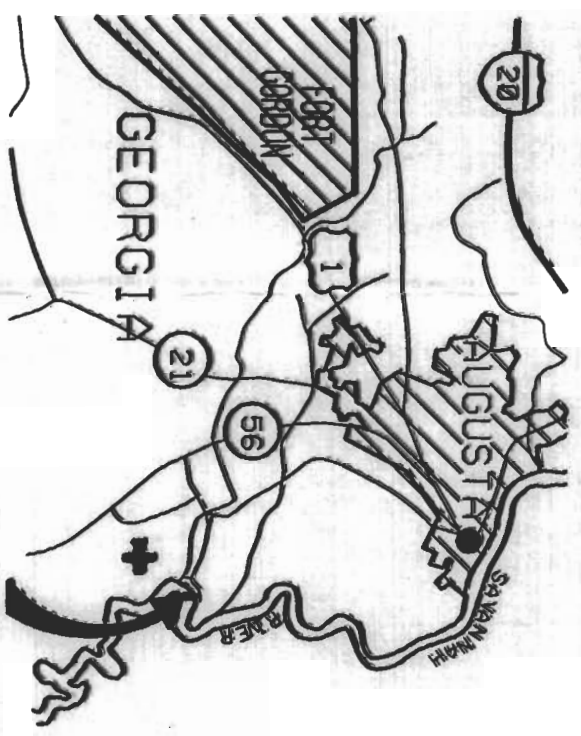
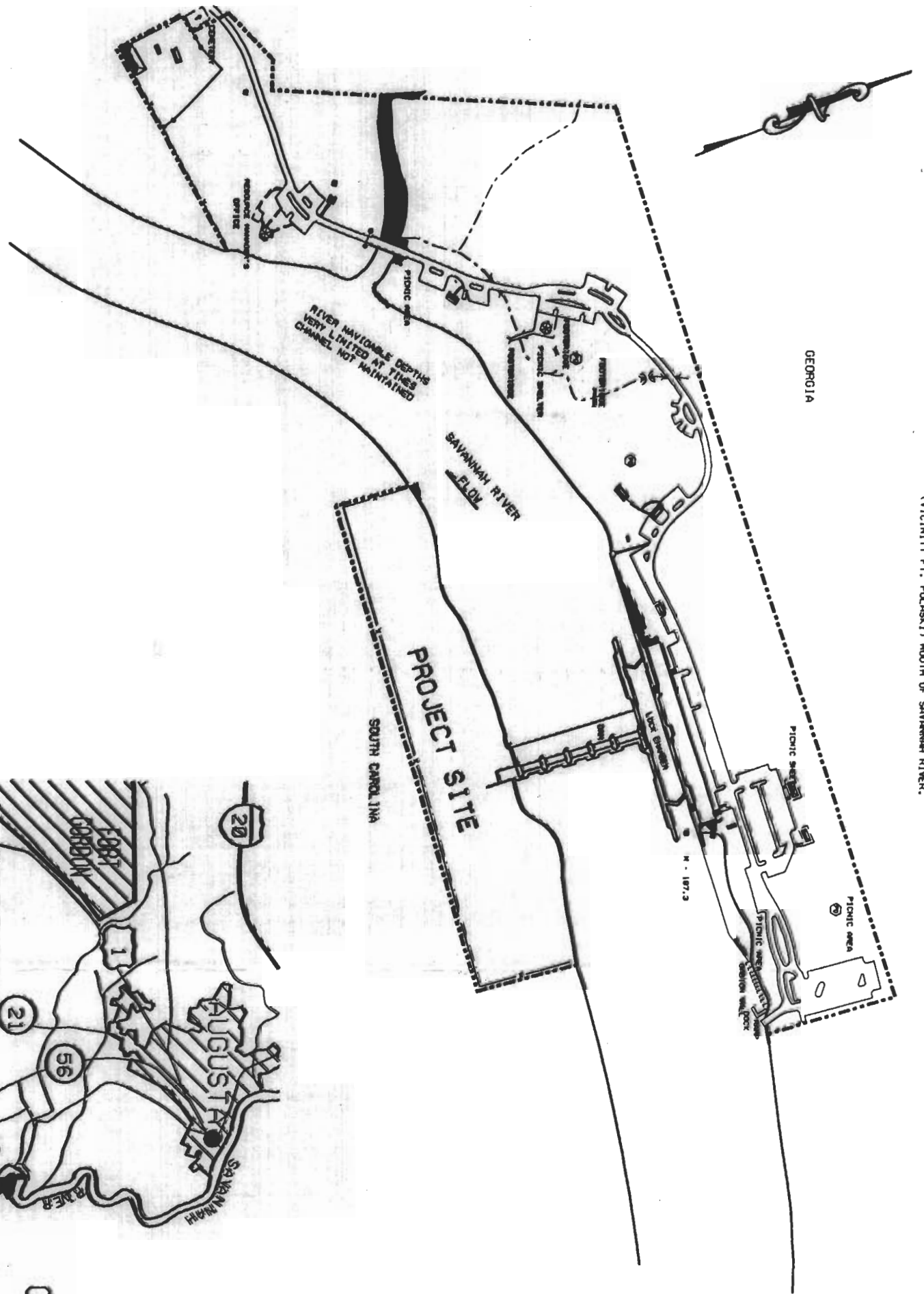

NEW SAVANNAH BLUFF
 LOCK AND DAM

PRELIMINARY
 FOR INFORMATION ONLY

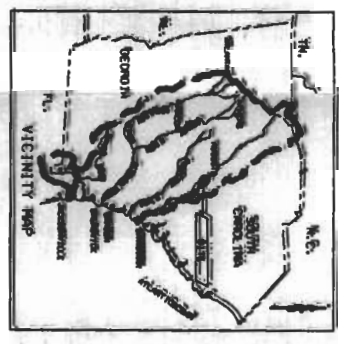

NO.	DATE	REVISIONS	BY	CHK'D	APP'D

NEW SAVANNAH BLUFF LOCK & DAM

FISH BYPASS SYSTEM
 PROJECT LOCATION MAP

DATE: _____
 DRAWN BY: _____
 CHECKED BY: _____
 APPROVED BY: _____

X 724500

X 724500

X 724750

X 725000

X 725250

X 725500

NEW SAVANNAH BLUFF LOCK AND DAM GEORGIA

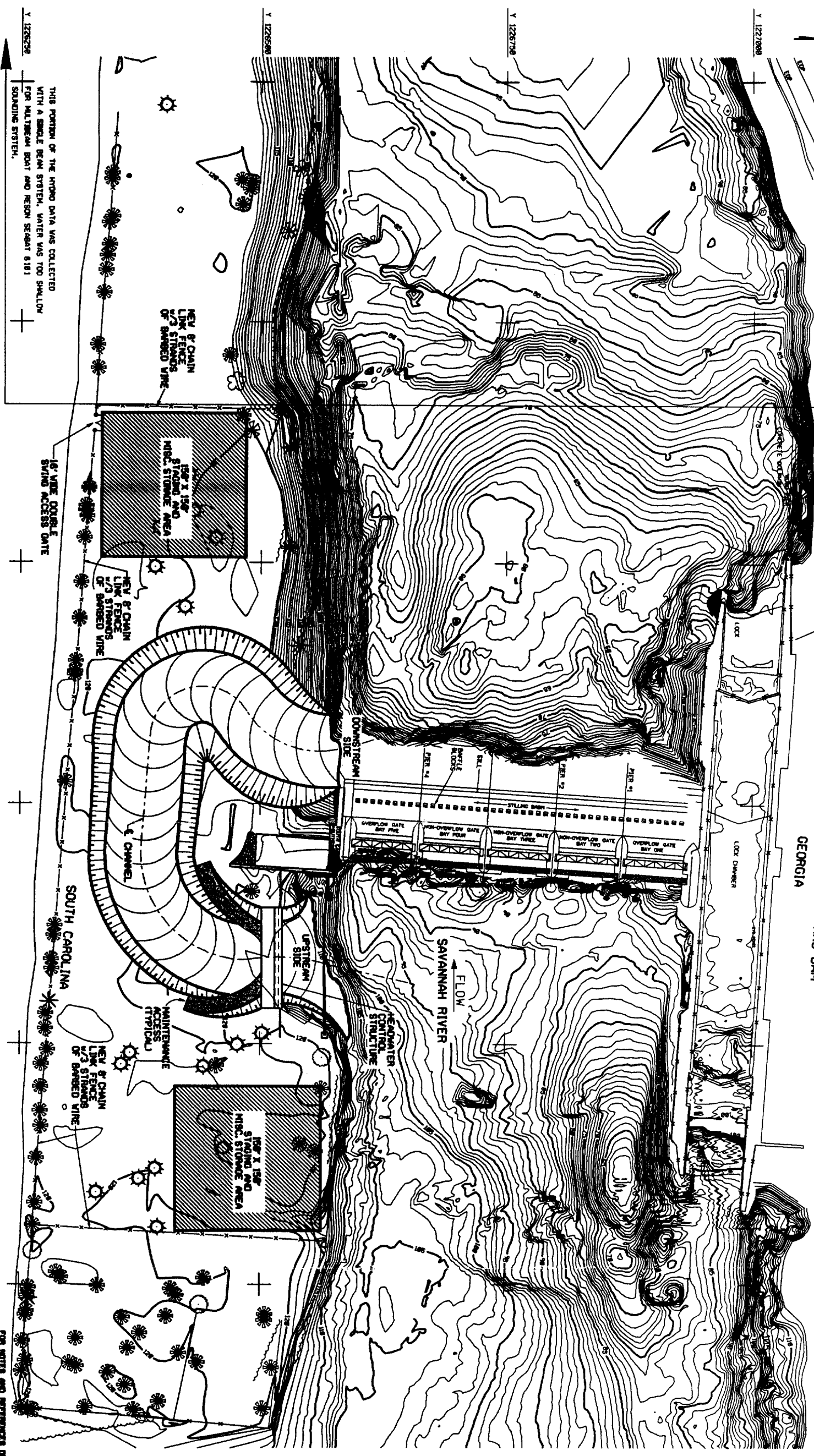

THIS PORTION OF THE HYDRO DATA WAS COLLECTED WITH A SINGLE BEAM SYSTEM. WATER WAS TOO SHALLOW FOR MULTIBEAM SONAR AND RESEARCH SCANNING SYSTEM.

PRELIMINARY FOR INFORMATION ONLY

FRAMATOME ANP
AS SHOWN ON SHEET
GENERAL ARRANGEMENT

NEW SAVANNAH BLUFF LOCK & DAM

FISH BYPASS SYSTEM
GENERAL ARRANGEMENT

NO.	REVISIONS	DATE	BY	CHKD.	DATE	BY	CHKD.	DATE	BY	CHKD.
1	ISSUED FOR CONSTRUCTION	05-10-00
2										
3										
4										
5										
6										
7										

NO.	REVISIONS	DATE	BY	CHKD.	DATE	BY	CHKD.	DATE	BY	CHKD.
1	ISSUED FOR CONSTRUCTION	05-10-00
2										
3										
4										
5										
6										
7										

DATE: 05-10-00
 DRAWN BY: ...
 CHECKED BY: ...
 TITLE: NEW SAVANNAH BLUFF LOCK & DAM

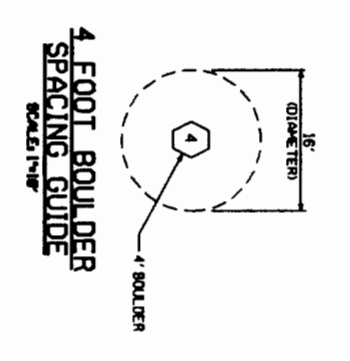
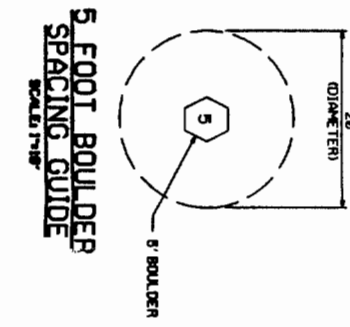
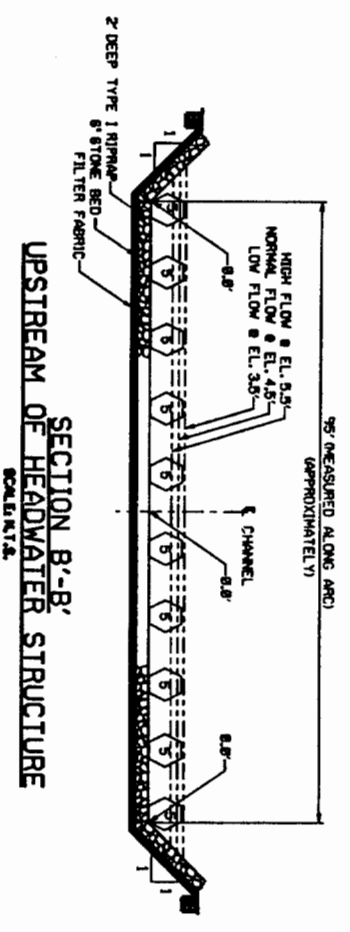
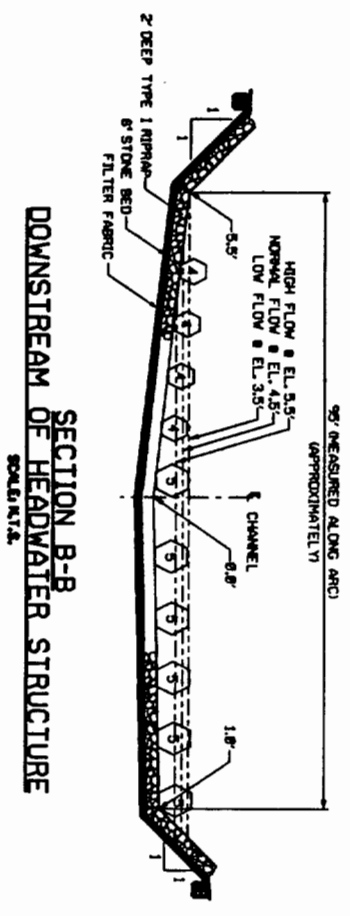
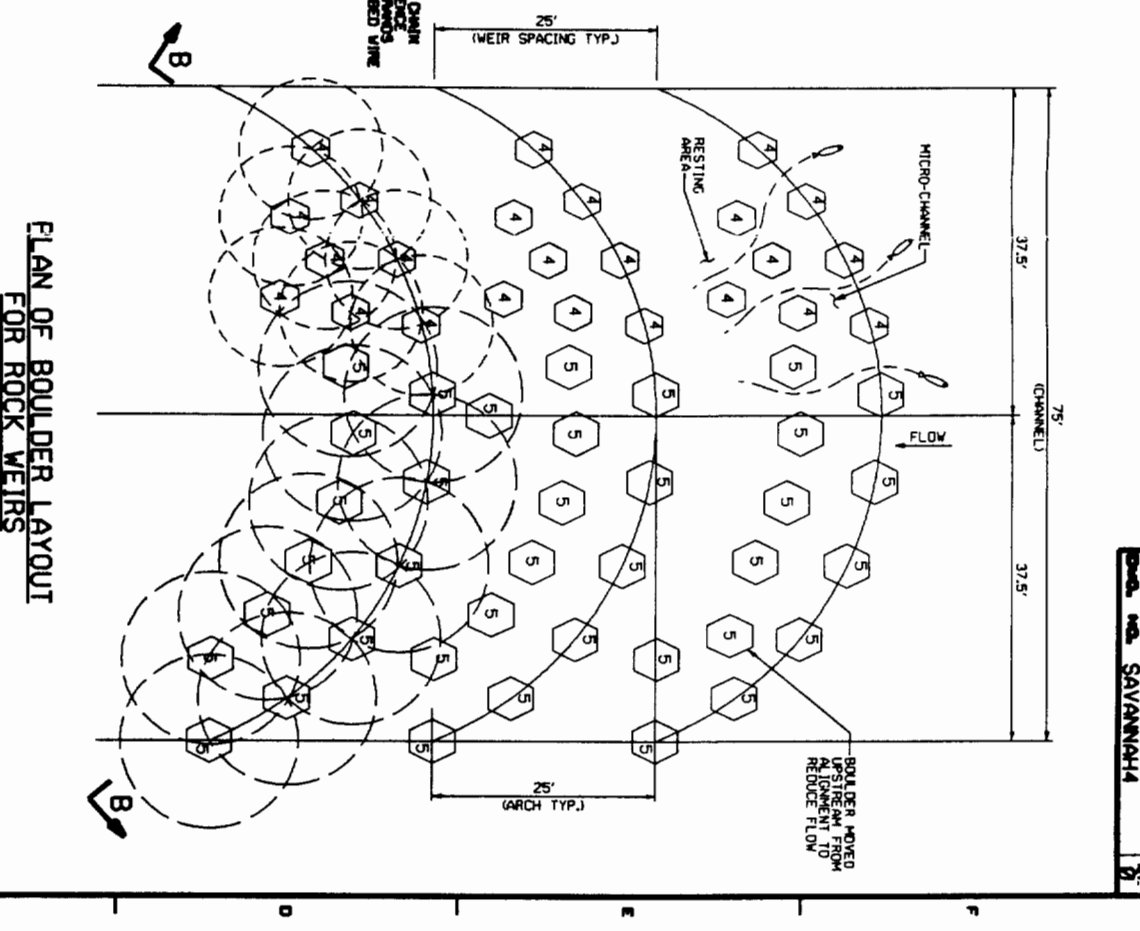
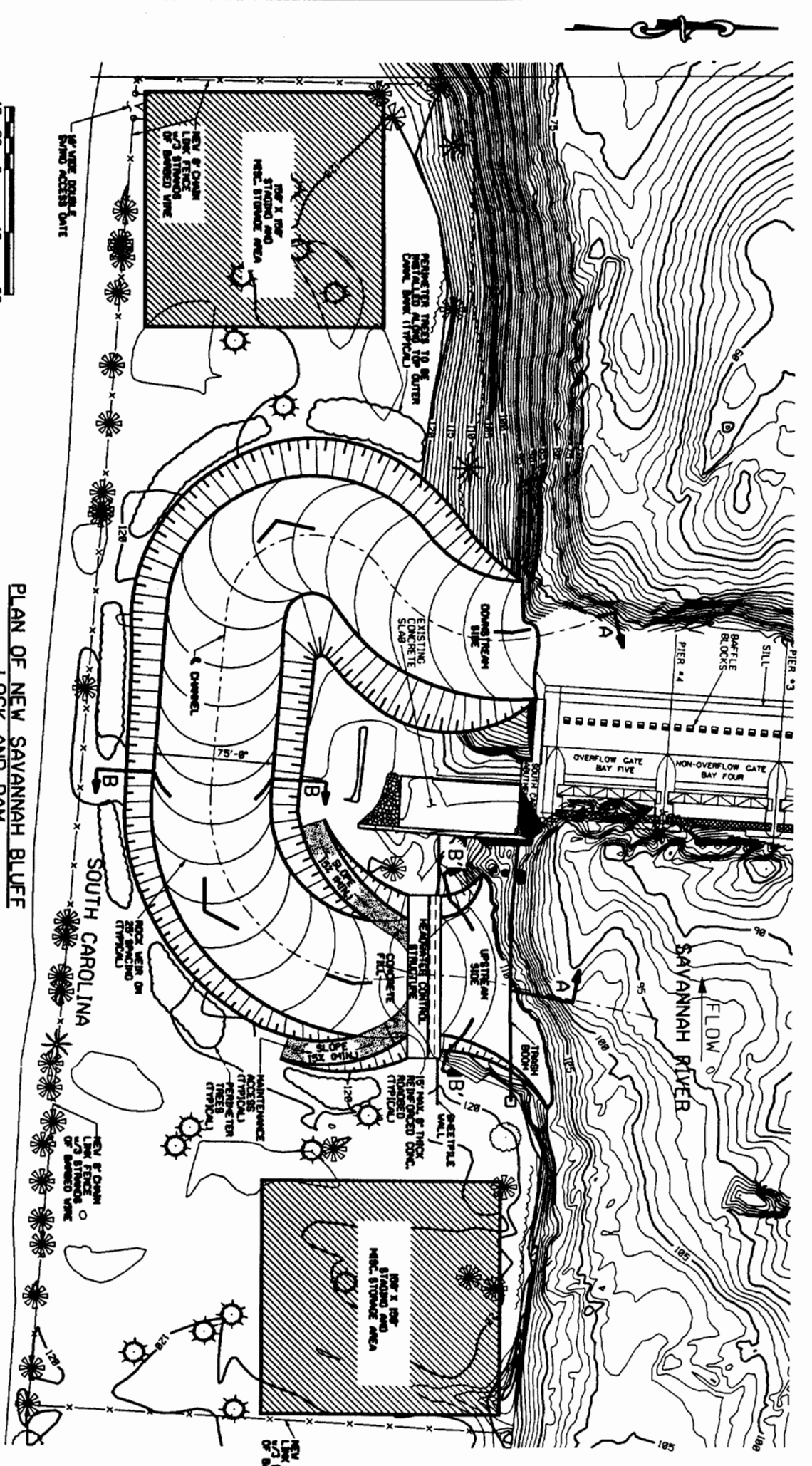

PLAN OF NEW SAVANNAH BLUFF LOCK AND DAM
SCALE: 1"=40'

PLAN OF BOULDER LAYOUT FOR ROCK WEIRS
SCALE: 1"=10'

NOTE:
ACCESS TO BE SHOWN LATER.

SECTION B-B
DOWNSTREAM OF HEADWATER STRUCTURE
SCALE: 1"=5'

SECTION B-B'
UPSTREAM OF HEADWATER STRUCTURE
SCALE: 1"=5'

PRELIMINARY FOR INFORMATION ONLY

NEW SAVANNAH BLUFF LOCK & DAM
FISH BYPASS SYSTEM CANAL

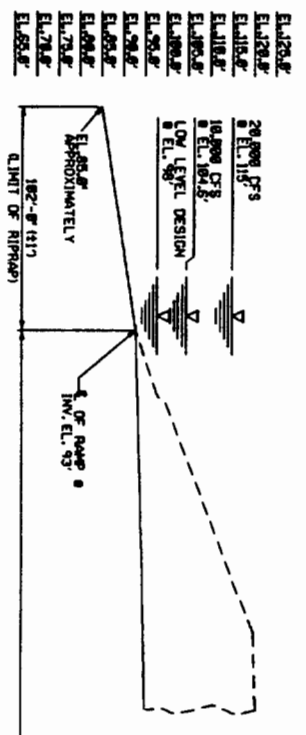

SECTION A-A
SCALE: 1"=50'

NO.	DESCRIPTION	DATE	BY	CHK'D	DATE	BY	APPROVED	DATE	BY
1	ISSUED FOR CONSTRUCTION	08-18-88
2	REVISIONS								

DESIGNER	CHECKED	DATE	DATE	DATE	DATE	DATE	DATE
...

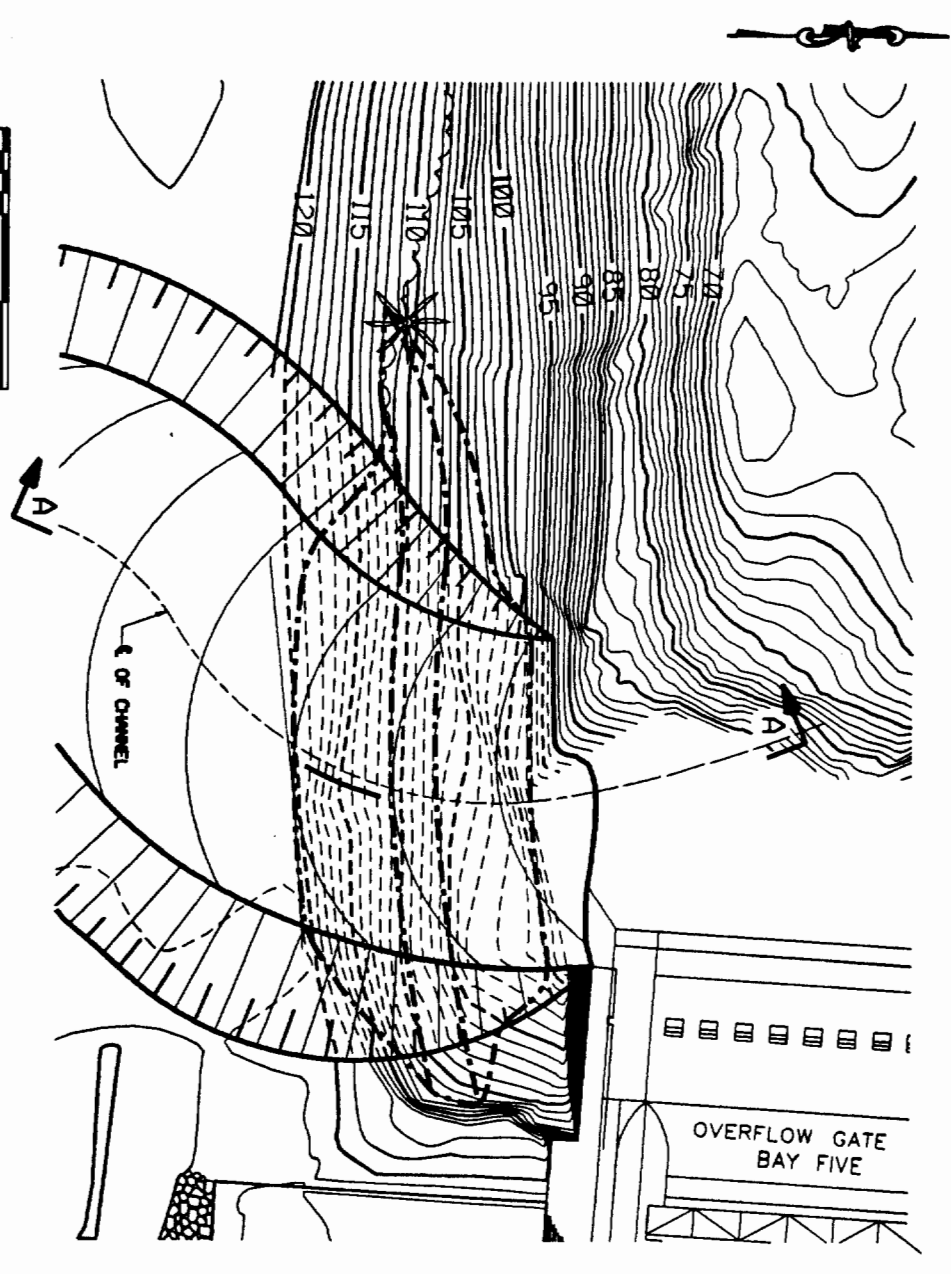

**PARTIAL PLAN OF
DOWNSTREAM SIDE OF
NEW SAVANNAH BLUFF
LOCK AND DAM**
SCALE: 1"=20'

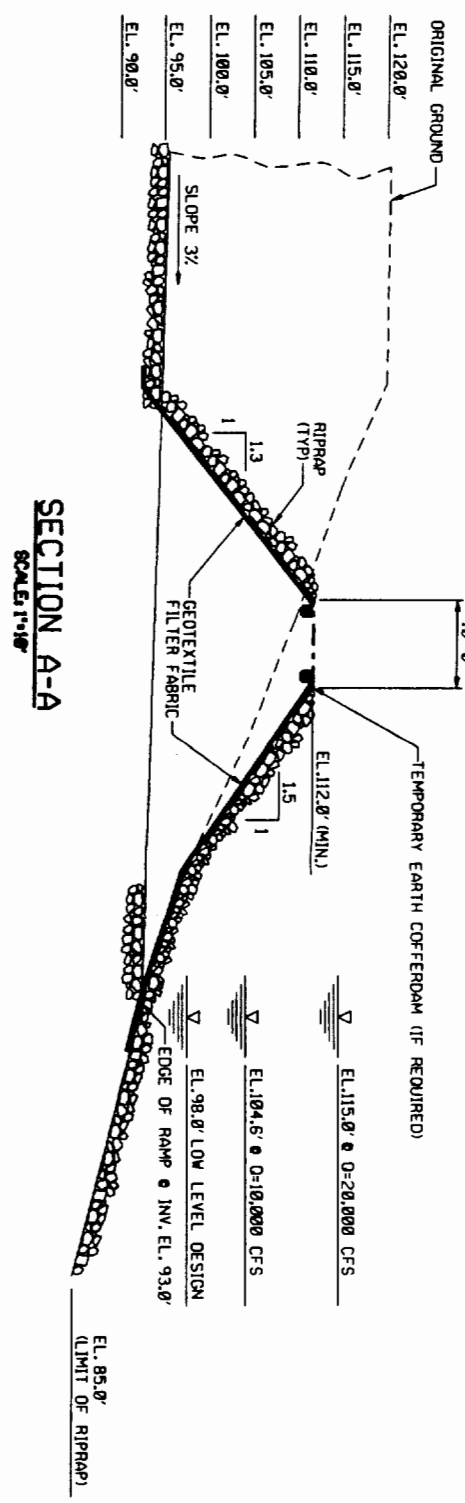

SECTION A-A
SCALE: 1"=10'

**PRELIMINARY
FOR INFORMATION ONLY**

FOR NOTES AND REFERENCES DRAWINGS SEE DRAWING

FRAMATOME ANP
240 SOUTH BAY STREET
FALMOUTH, MA 02540
TEL: 508.546.3000
FAX: 508.546.3001
WWW.FRAMATOME.COM

NEW SAVANNAH BLUFF LOCK & DAM

**FISH BYPASS SYSTEM
CANAL, DOWNSTREAM ENTRANCE
PLAN, SECTIONS & DETAILS**

NO.	REVISIONS	DATE	BY	CHKD	APPV	CARE	DATE	BY	CHKD	APPV	CARE
1	ISSUED FOR CONSTRUCTION	08-14-08									
2											
3											
4											
5											
6											
7											
8											
9											
10											

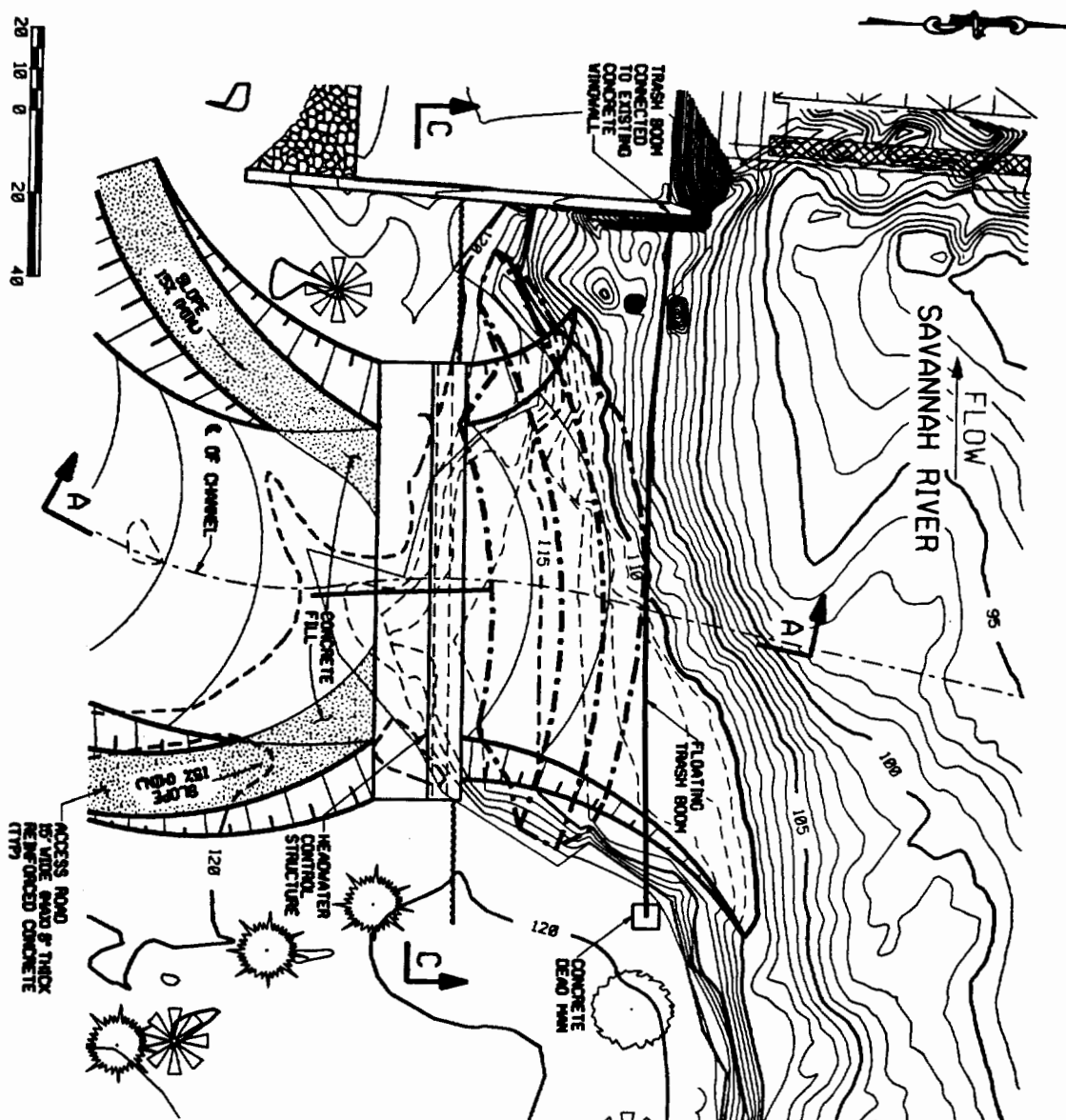

PARTIAL PLAN OF UPSTREAM SIDE OF NEW SAVANNAH BLUFF LOCK AND DAM
SCALE: 1"=20'

SECTION B-B (TYPICAL GATE SECTION)
SCALE: N.T.S.

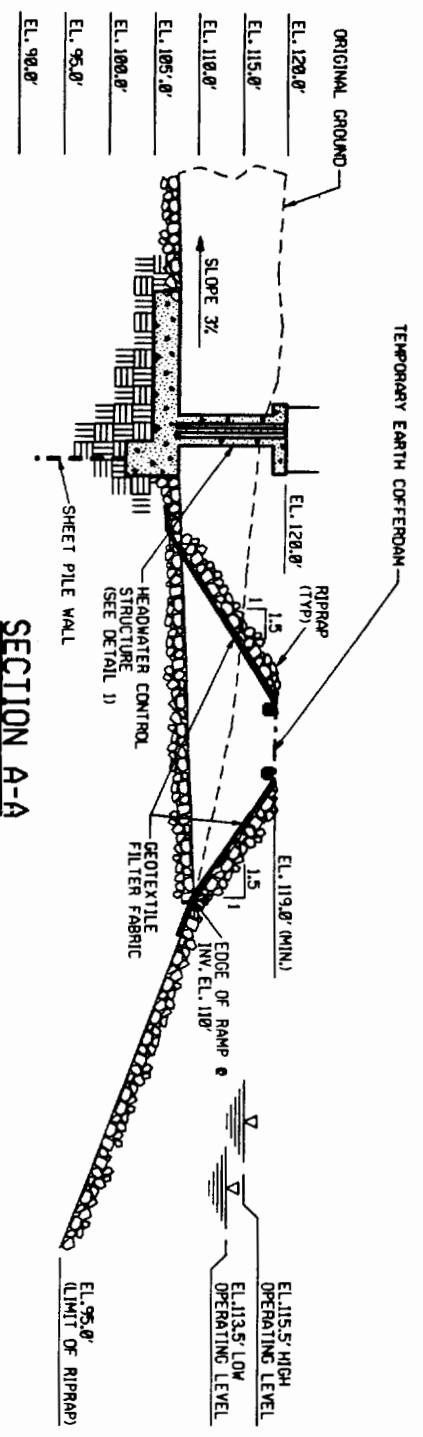
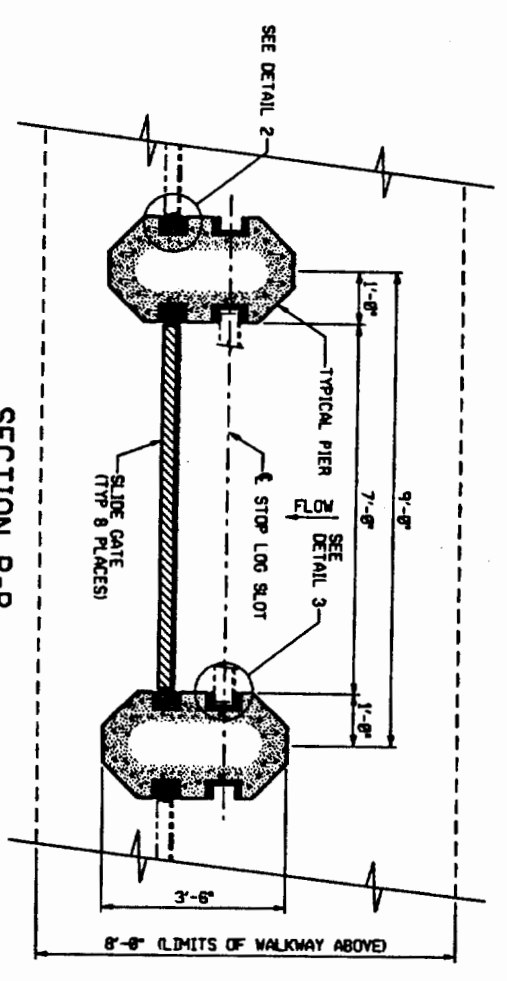

SECTION A-A
SCALE: 1"=10'

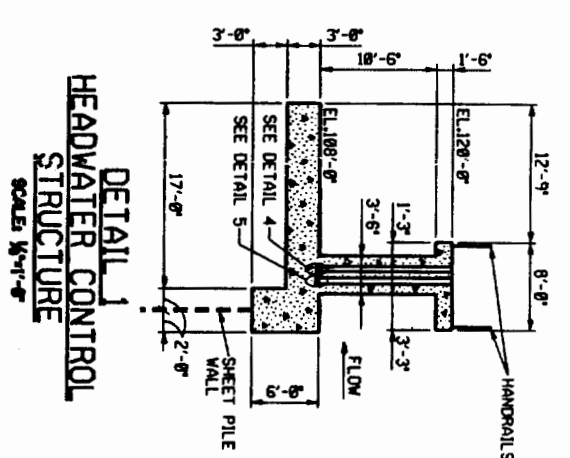

DETAIL 1 HEADWATER CONTROL STRUCTURE
SCALE: 1/4"=1'-0"

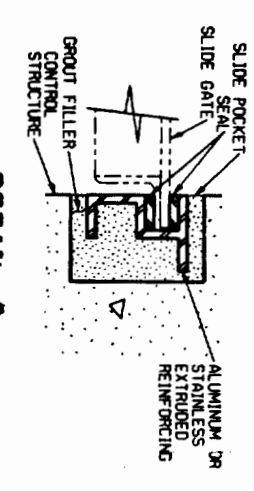

DETAIL 2 SLIDE GATE SEAL
SCALE: 3/4"=1'-0"

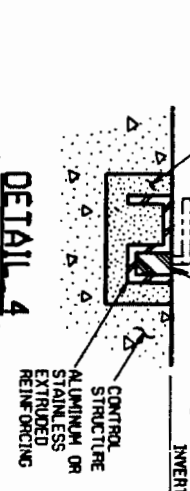

DETAIL 4 SLIDE GATE EMBEDDED INVERT
SCALE: 3/4"=1'-0"

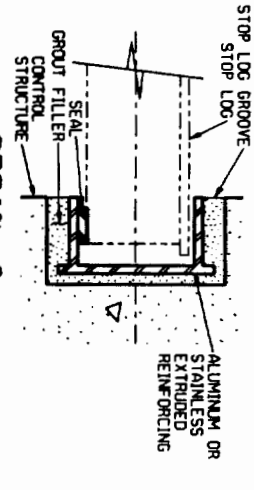

DETAIL 3 STOP LOG GROOVE
SCALE: 3/4"=1'-0"

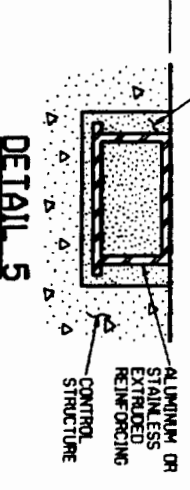

DETAIL 5 STOP LOG EMBEDDED INVERT
SCALE: 3/4"=1'-0"

PRELIMINARY FOR INFORMATION ONLY

SECTION C-C
SCALE: 1"=10'

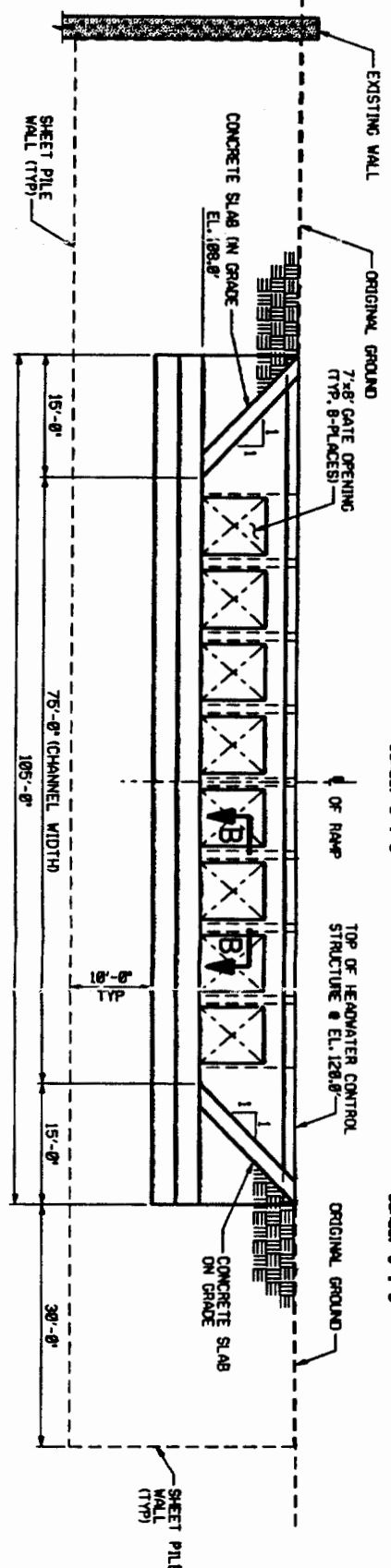

FOR NOTES AND REFERENCES, REFER TO SEE DRAWING
FRAMATOME ANP AS SHOWN ON SHEET P. 2, SEE NOTE FOR LOCATION OF DAM
NEW SAVANNAH BLUFF LOCK & DAM

NO.	DATE	BY	CHKD.	APP'D.	REVISIONS
1					ISSUED FOR CONSTRUCTION
2					
3					
4					
5					
6					
7					
8					
9					
10					
11					
12					
13					
14					
15					
16					
17					
18					
19					
20					

FISH STRAYS SYSTEM
CANAL UPSTREAM EXIT
PLAN, SECTIONS & DETAILS

SAVANNAH, GA.
NOV. 1968
DRAWING NO. SAVANNAH 6

Appendix B - Boring Logs

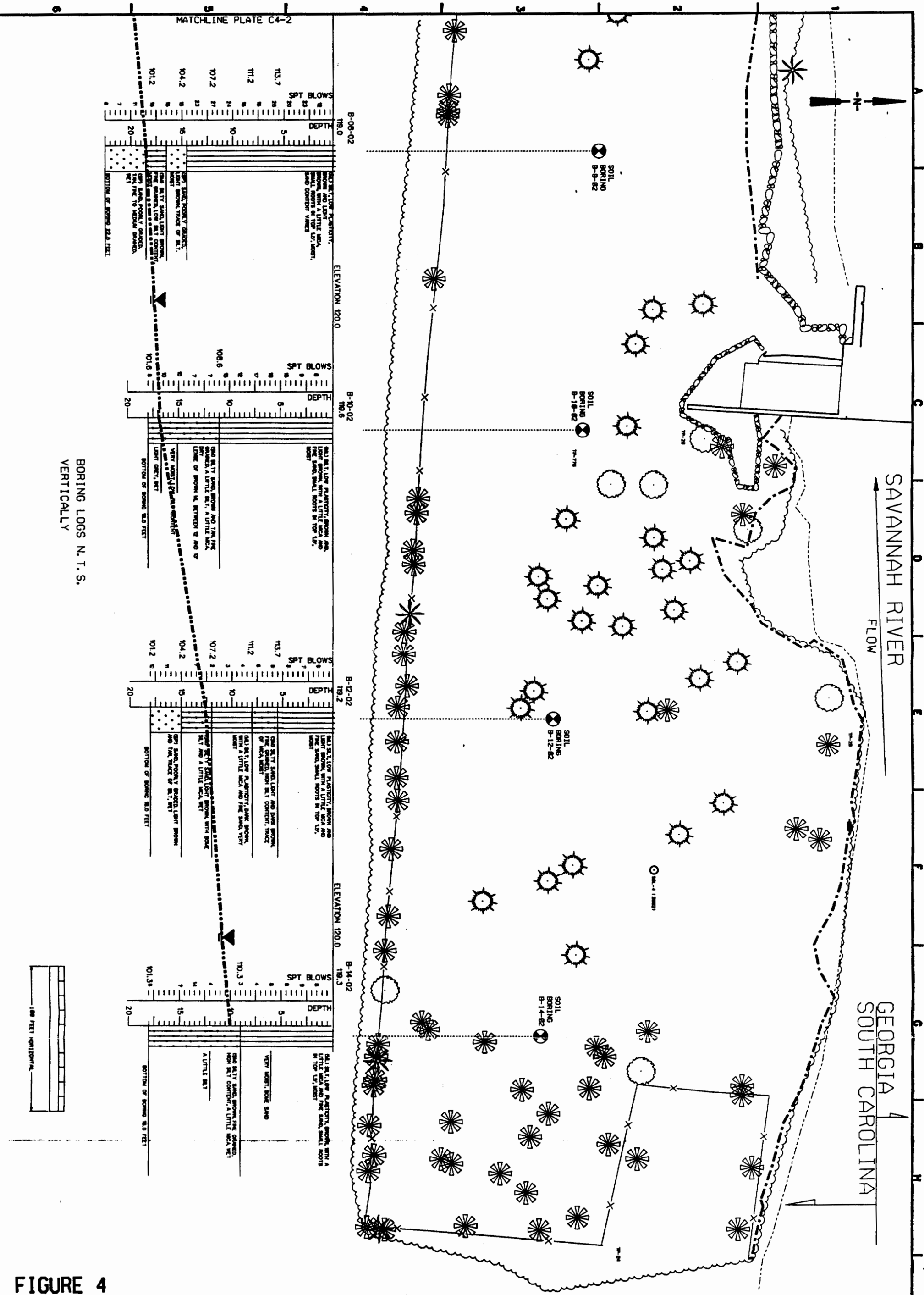
FIGURE 4

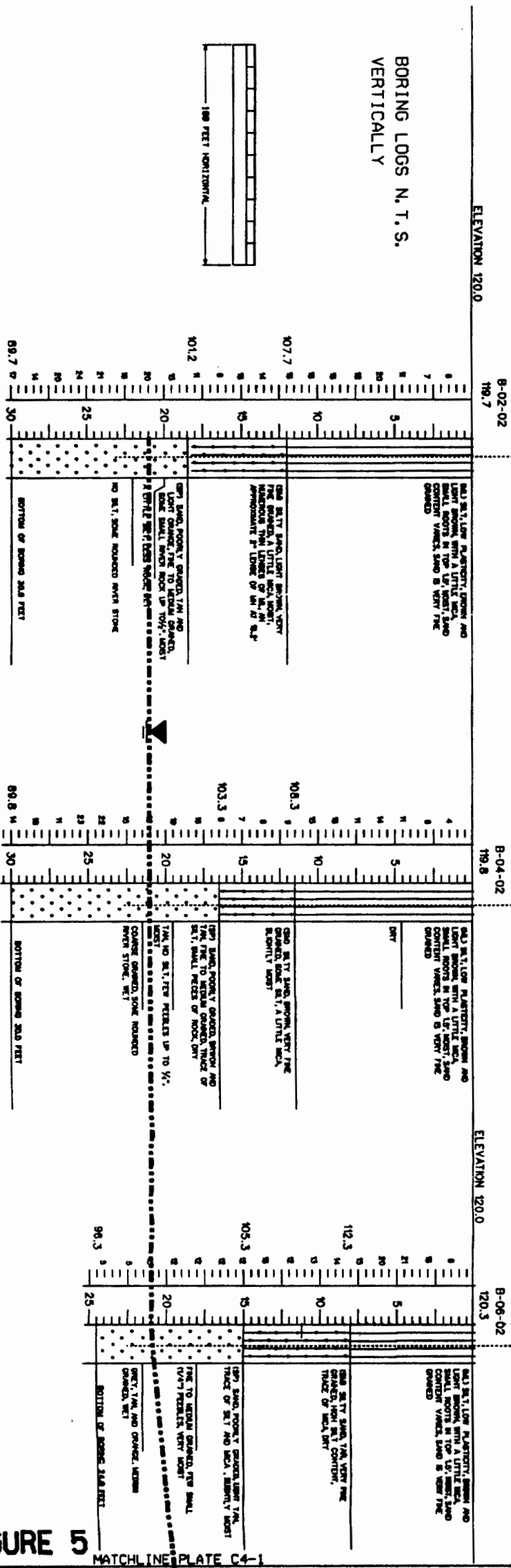
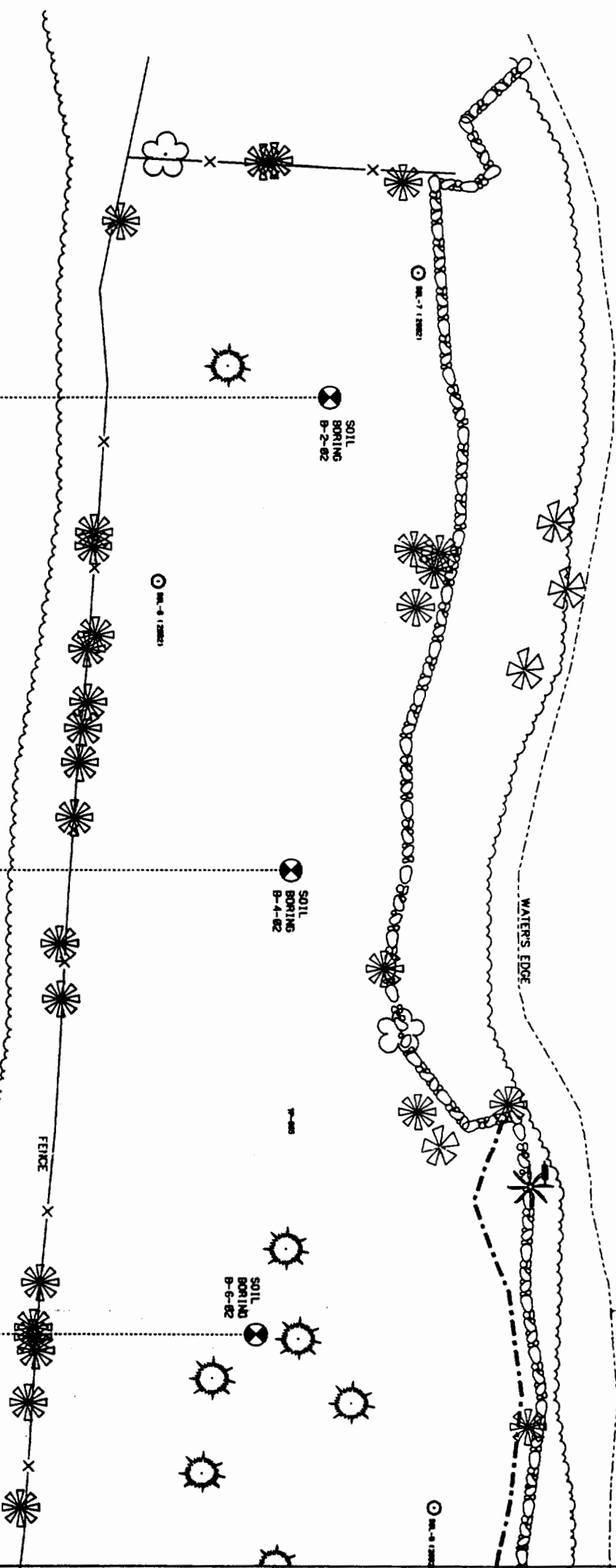
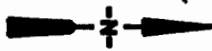
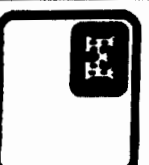

FIGURE 5
MATCHLINE PLATE C4-1
NEW SAVANNAH BLUFF LOCK & DAM, AUGUSTA, GA
BORING LOGS AND LOCATION PLAN
FISH BYPASS STRUCTURE

NOV 2002	
PLATE C4-2 OF 2	



Appendix C - Site Photographs



**Photo 1 – Distant view of left
abutment upstream of Dam**

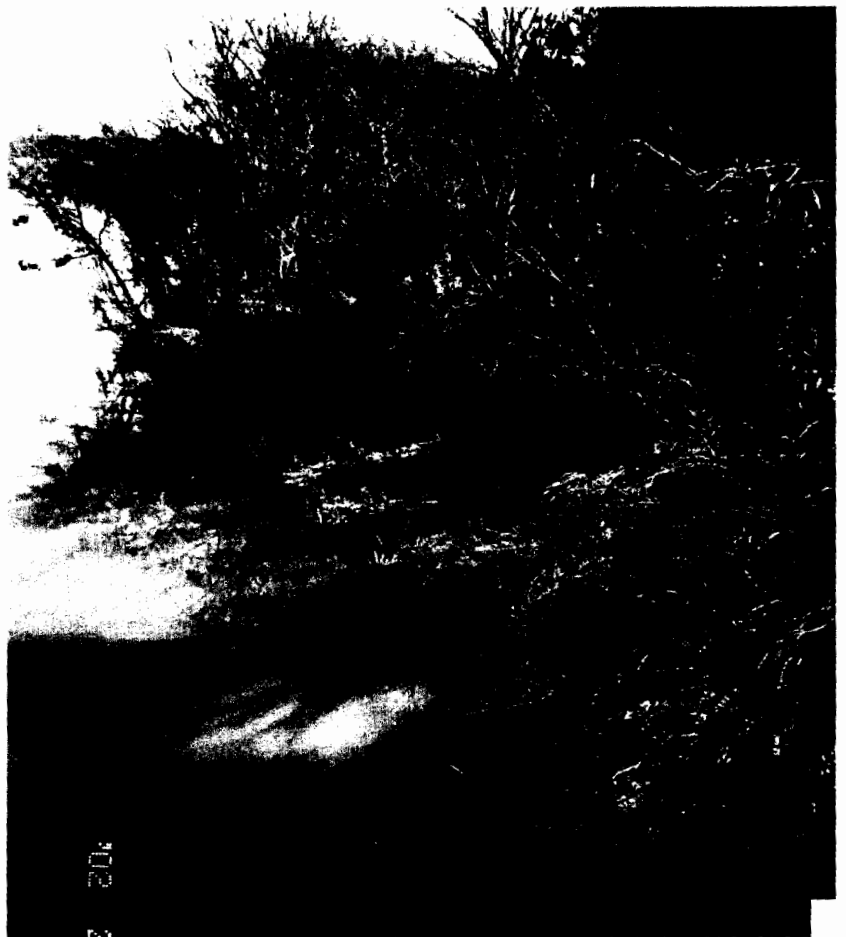

**Photo 2 - View of left
abutment just
upstream of Dam**



Photo 3 – View of left abutment just upstream of Dam



Photo 4 – View of left abutment just upstream of Dam



Photo 5 – View of left abutment area from Dam Structure



Photo 6 – View of left abutment area



Photo 7 – View of left abutment area just downstream of Dam



Photo 8 – View of left abutment area downstream of Dam

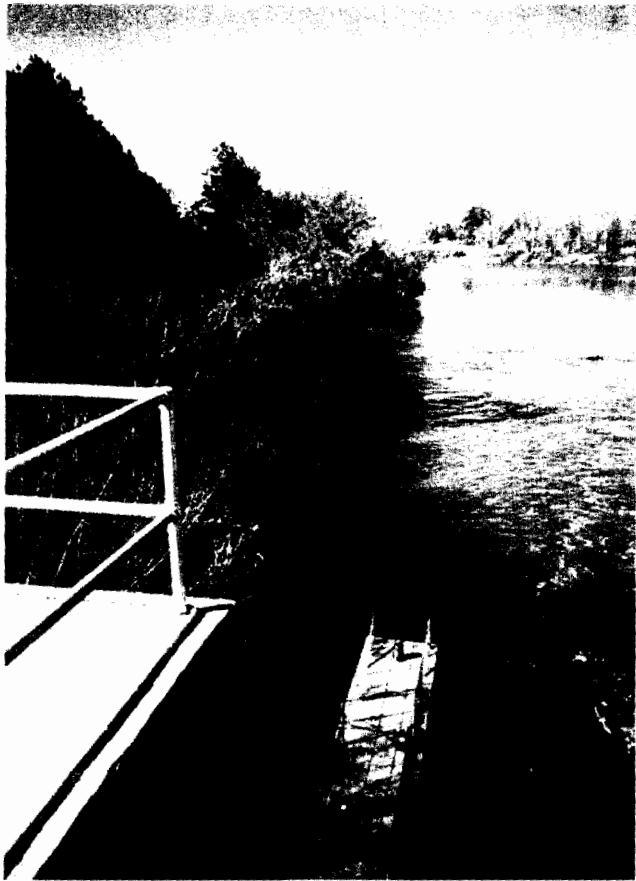

**Photo 9 – View of left
abutment area
downstream of Dam**



Photo 10 – View of Spillway Gate No. 5 near turn

Appendix D - Material Quantity Estimates

**This Section Intentionally Left Blank
See Section VI for Material Quantity Estimate**

Appendix E – Hydrology

Note:

Headwater Gauge Datum = 100.58 (NGVD)

Tailwater Gauge Datum = 96.58 (NGVD)

Upper Pool Duration Curve
Butler Creek Upper Pool (08:00) 1/1/1992 - 4/2/2002

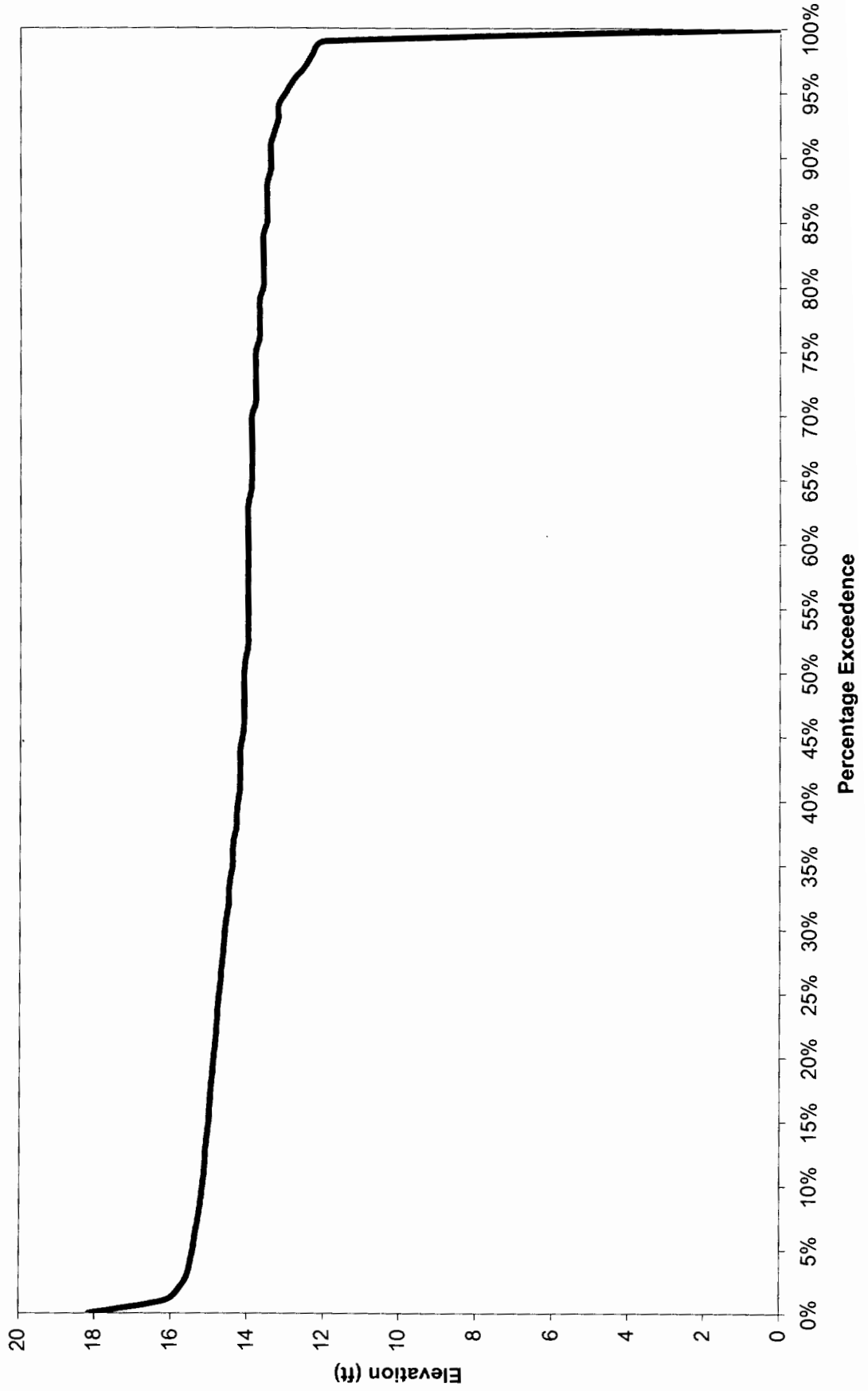

Tailwater Duration Curve

Butler Creek Tail Water (08:00) 1/1/1992 - 4/2/2002

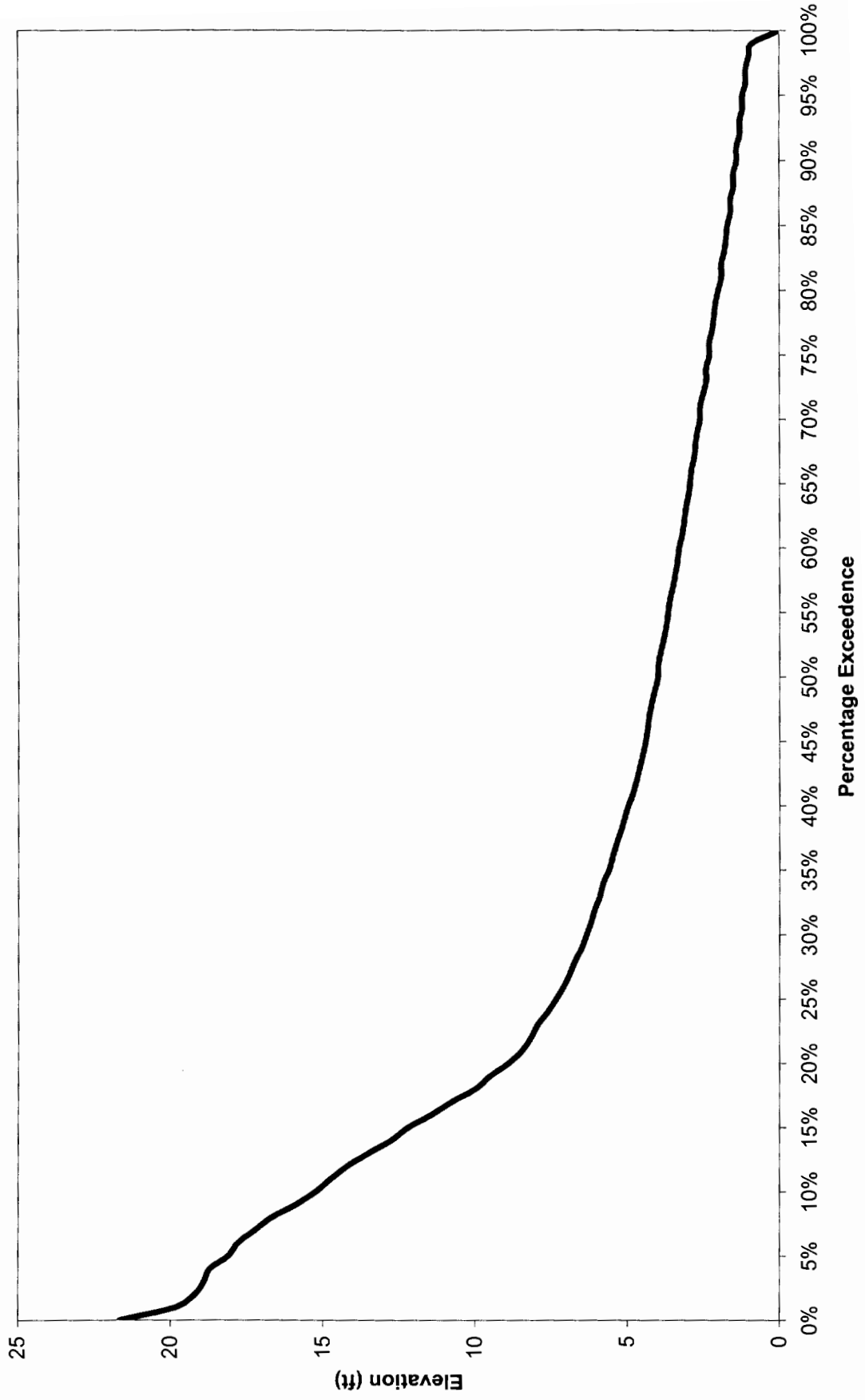

Average Year Flows

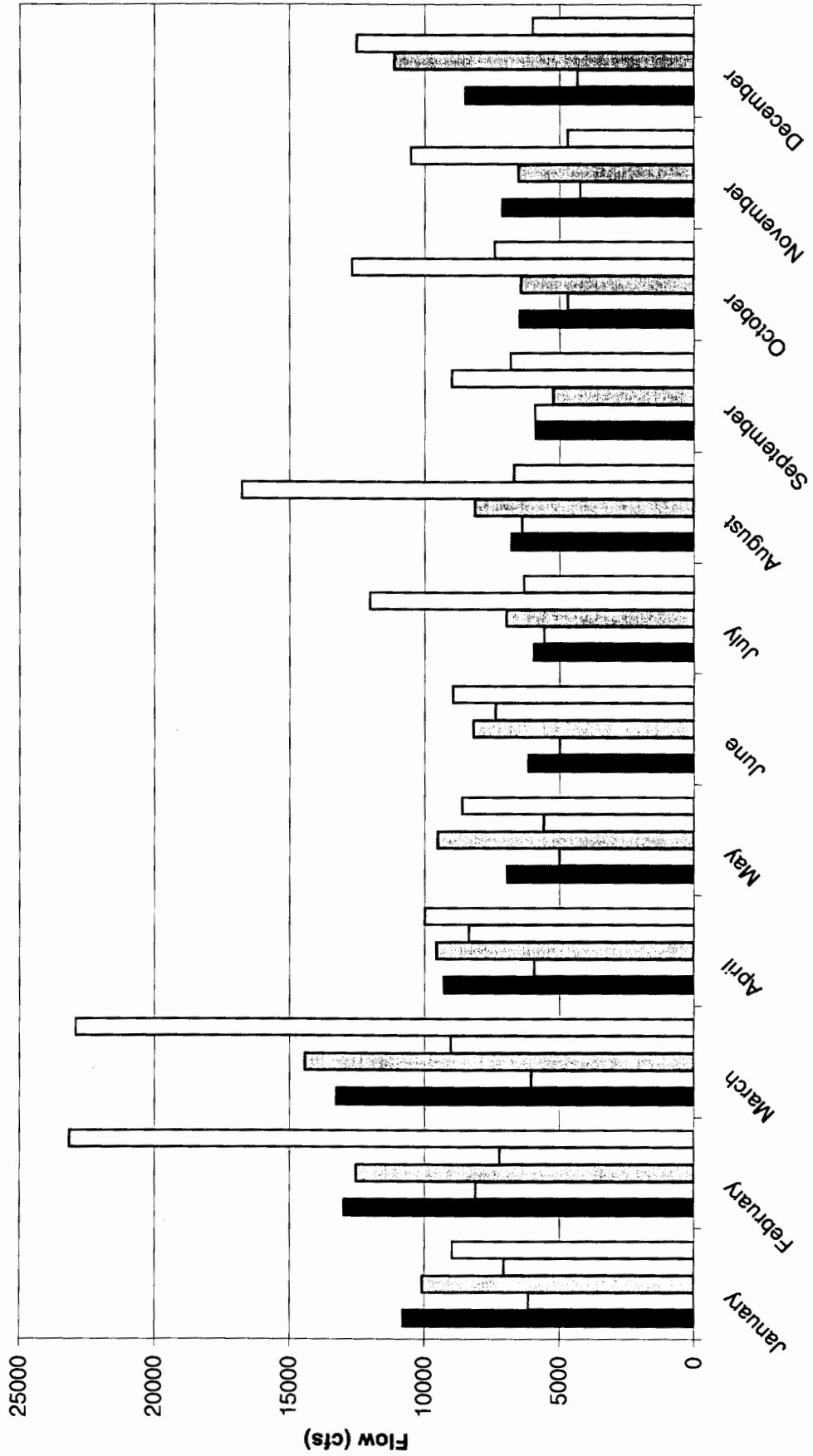

■ Average Year □ 1999 □ 1997 □ 1994 □ 1996

Butler Creek Discharge Duration Curve

Butler Creek Discharge 1/1/1992 - 4/2/2002

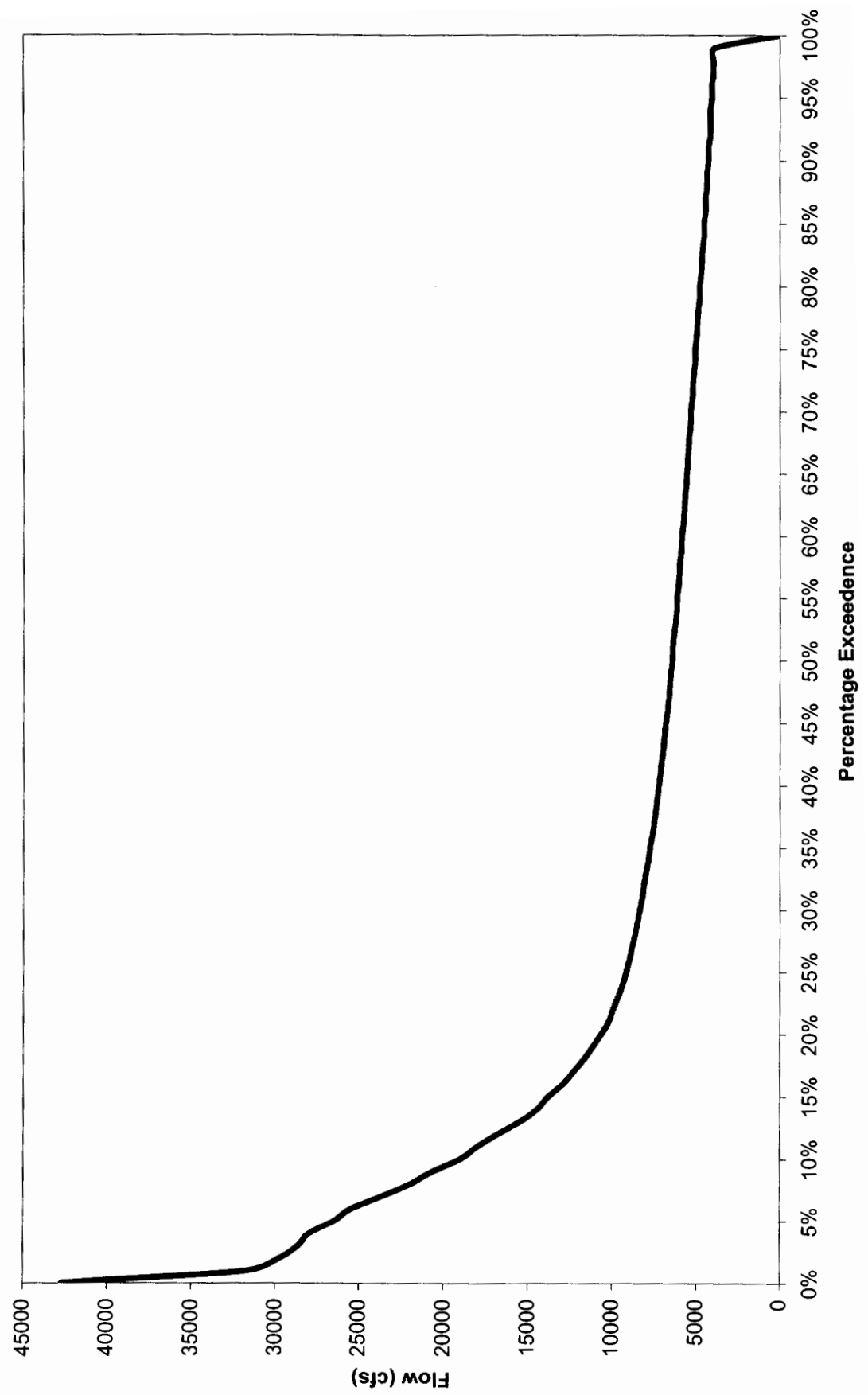

Butler Creek January Flow Duration Curve
1/1/1992 - 4/2/2002

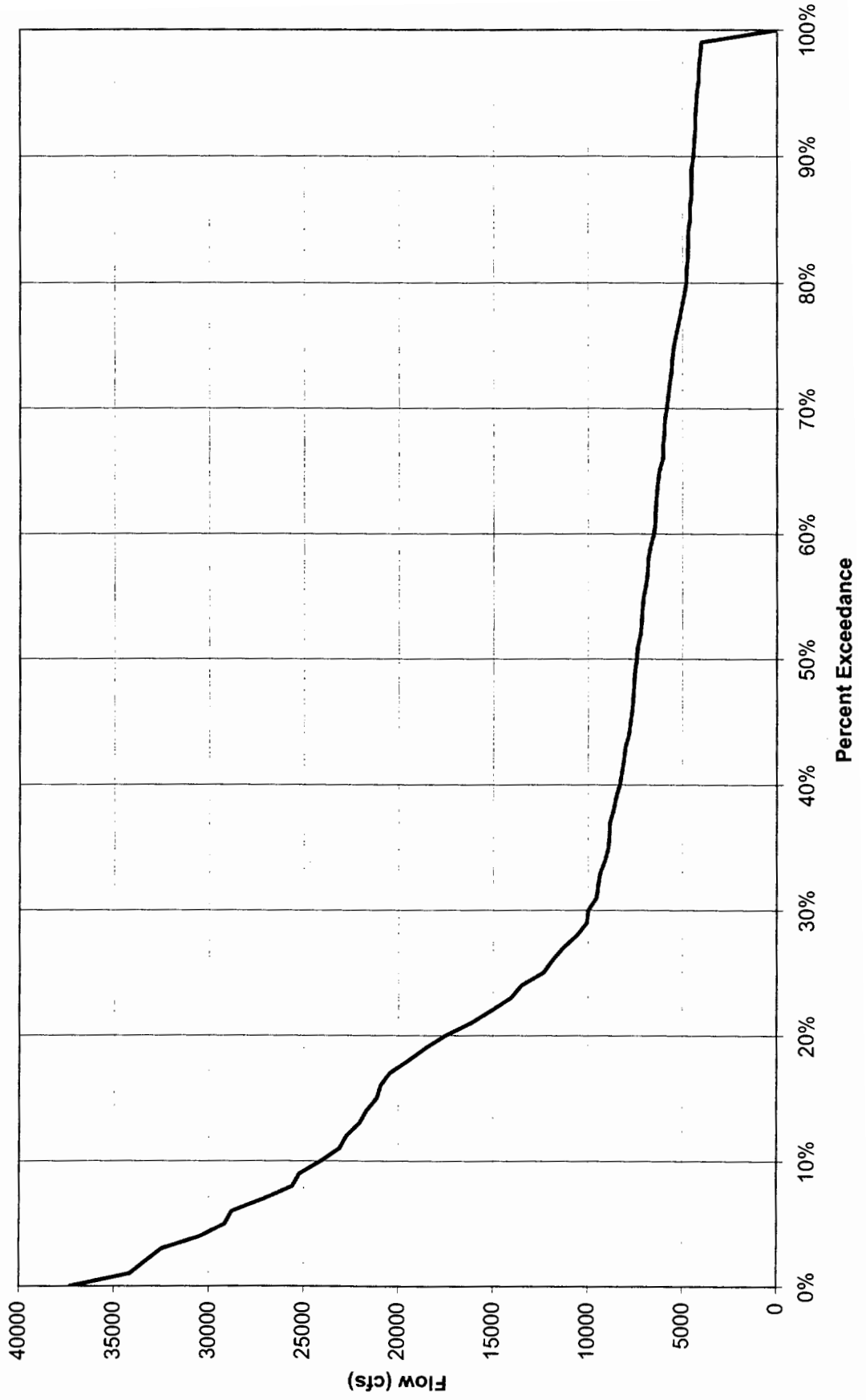

Butler Creek February Flow Duration Curve
1/1/1992 - 4/2/2002

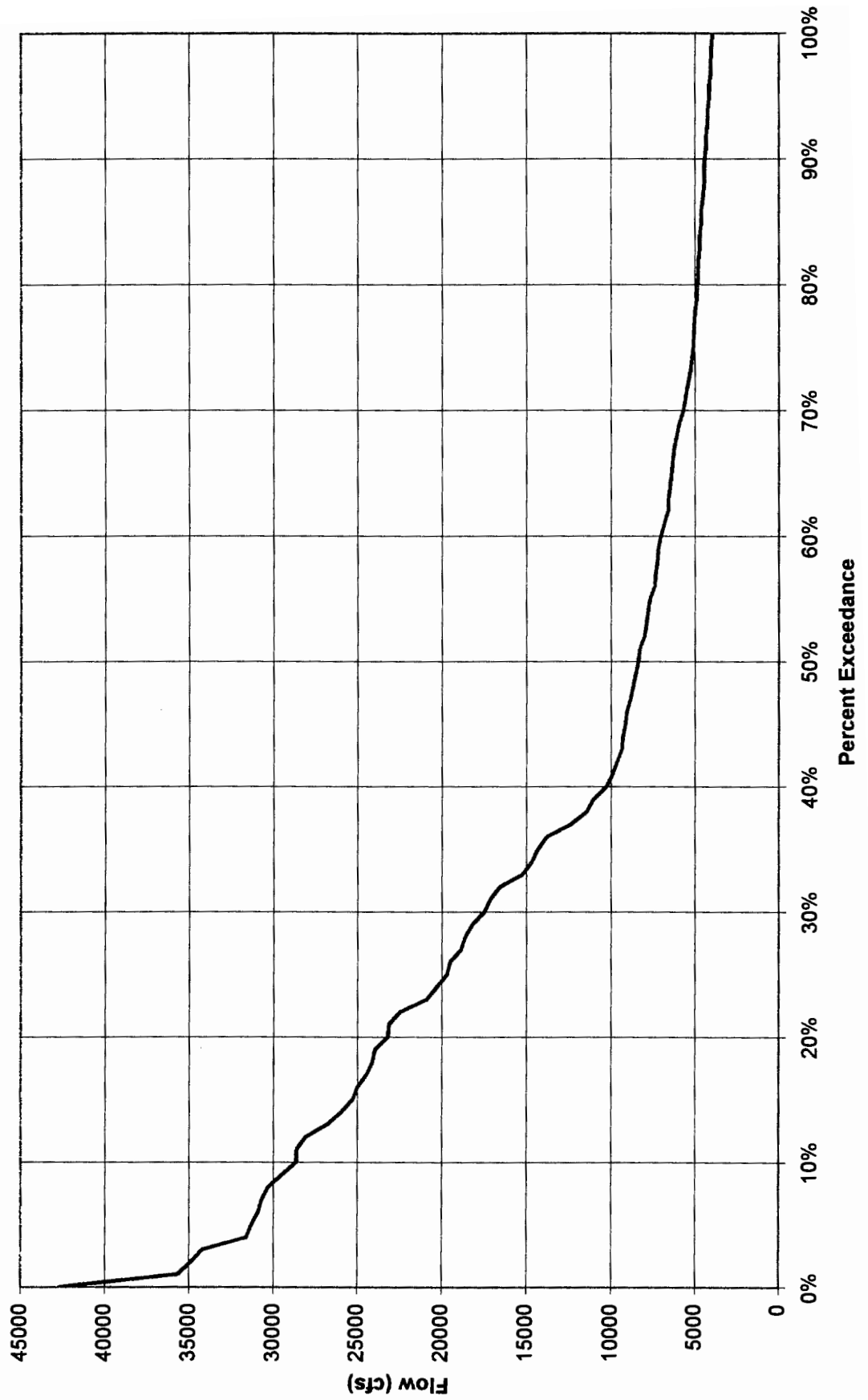

**Butler Creek March Flow Duration Curve
1/1/1992 - 4/2/2002**

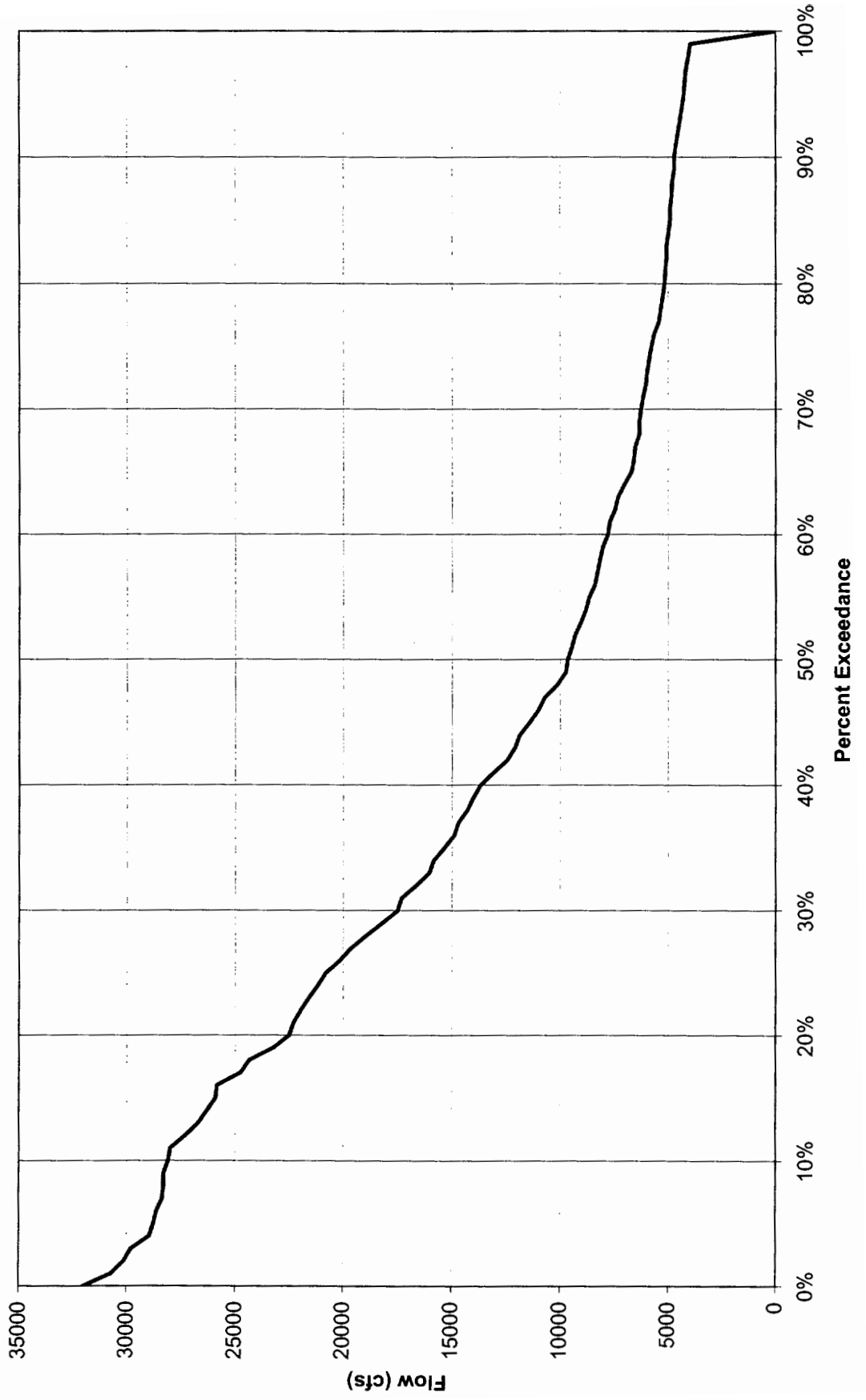

Butler Creek April Flow Duration Curve
1/1/1992 - 4/2/2002

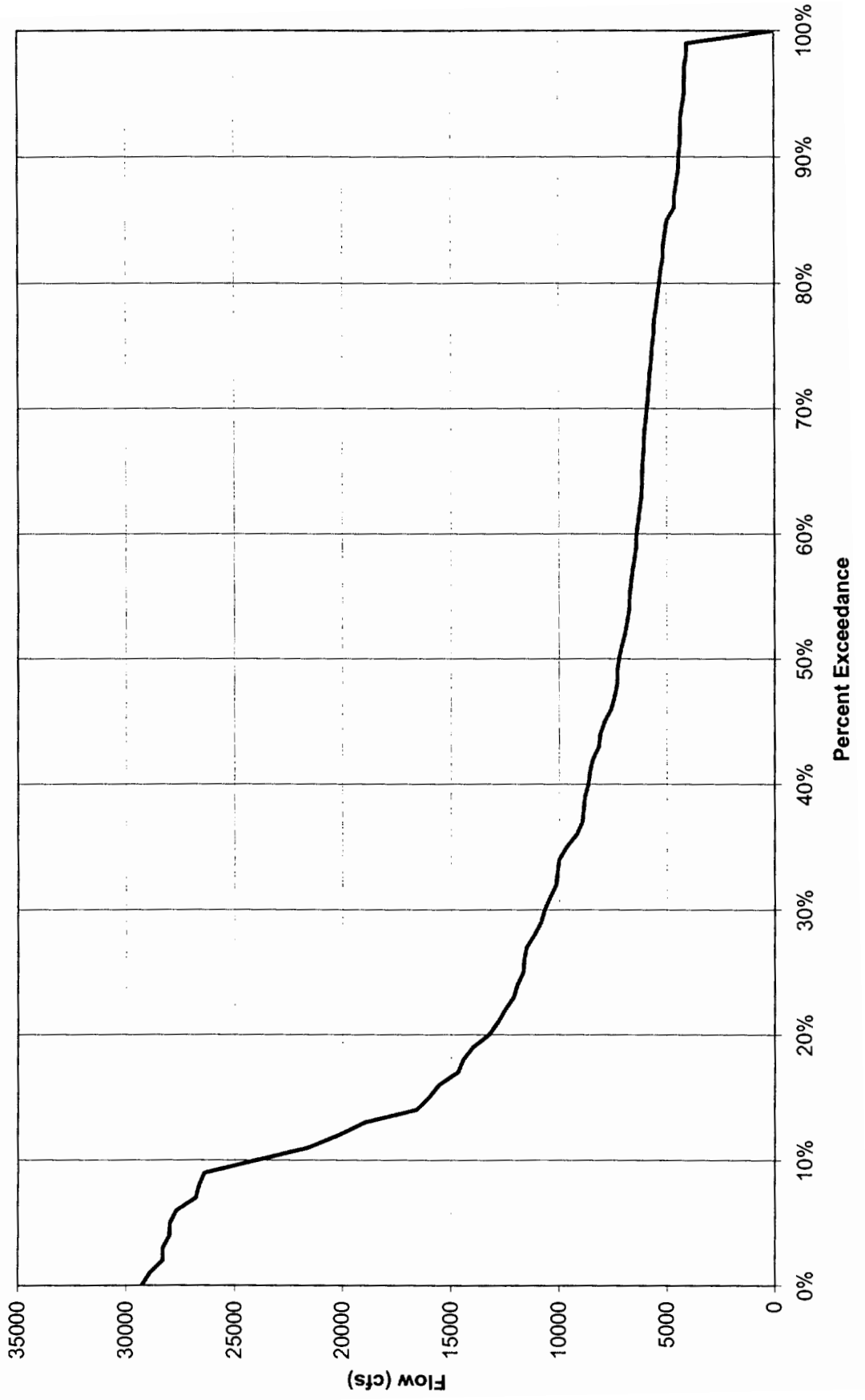

**Butler Creek May Flow Duration Curve
1/1/1992 - 4/2/2002**

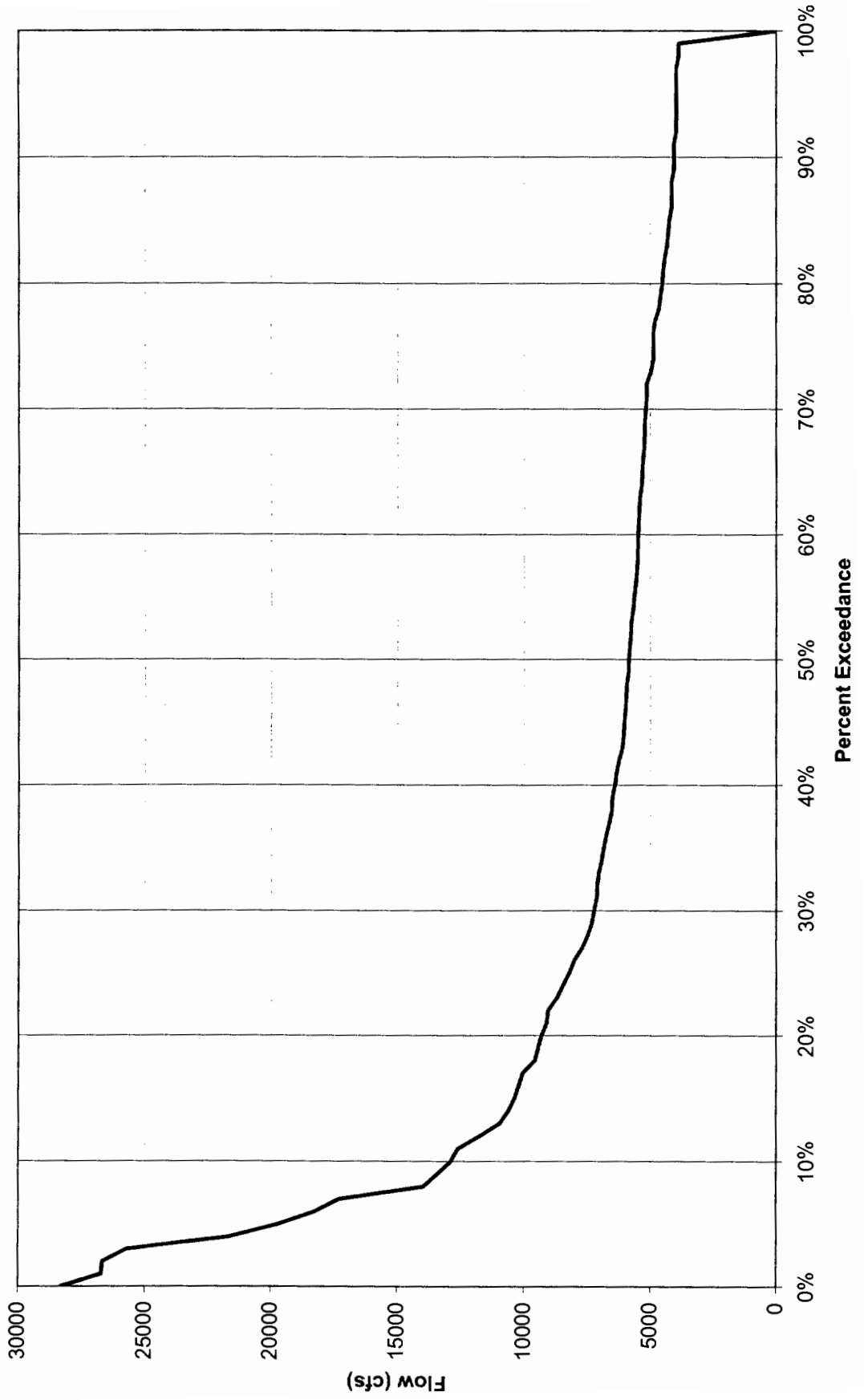

**Butler Creek June Flow Duration Curve
1/1/1992 - 4/2/2002**

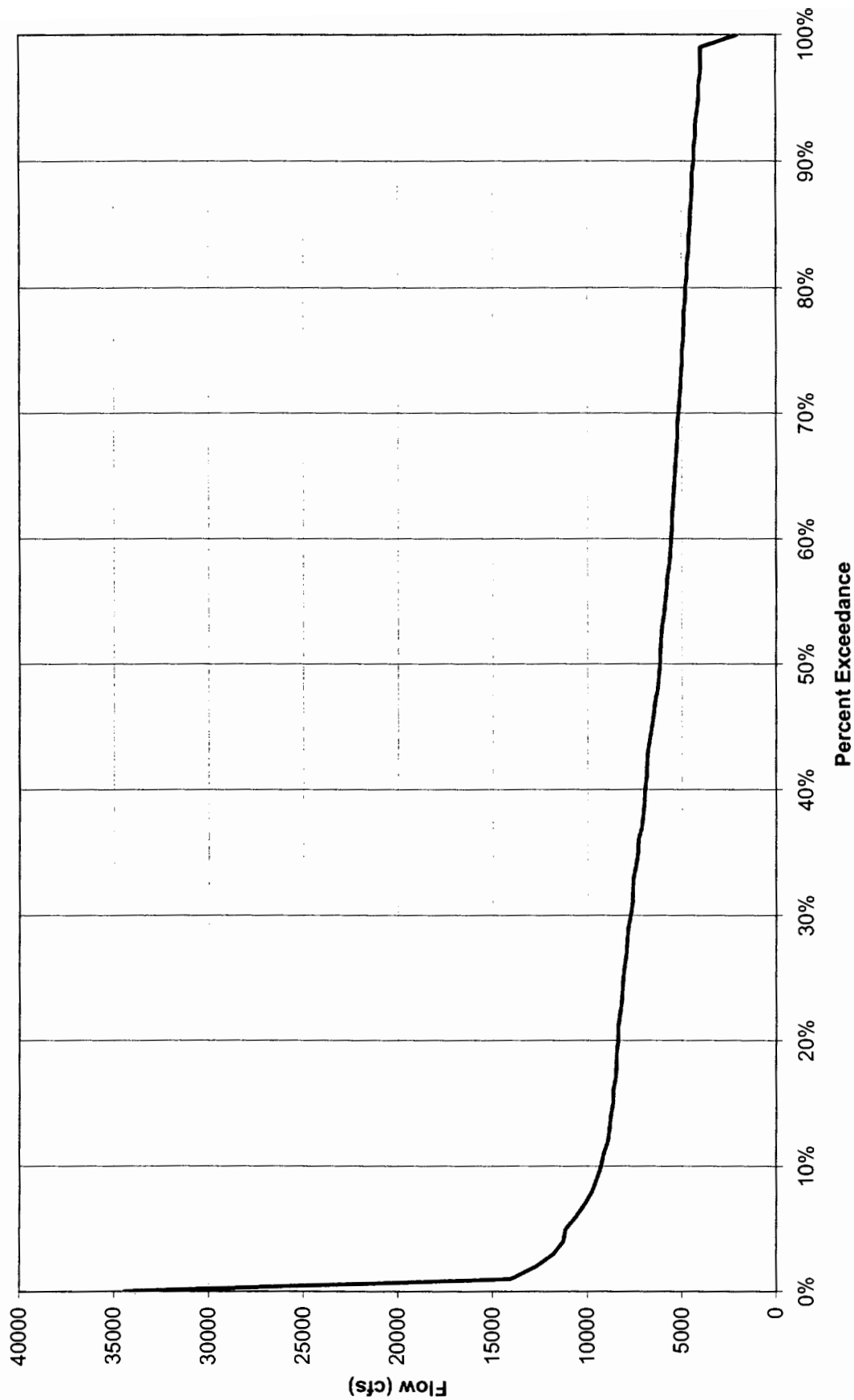

**Butler Creek July Flow Duration Curve
1/1/1992 - 4/2/2002**

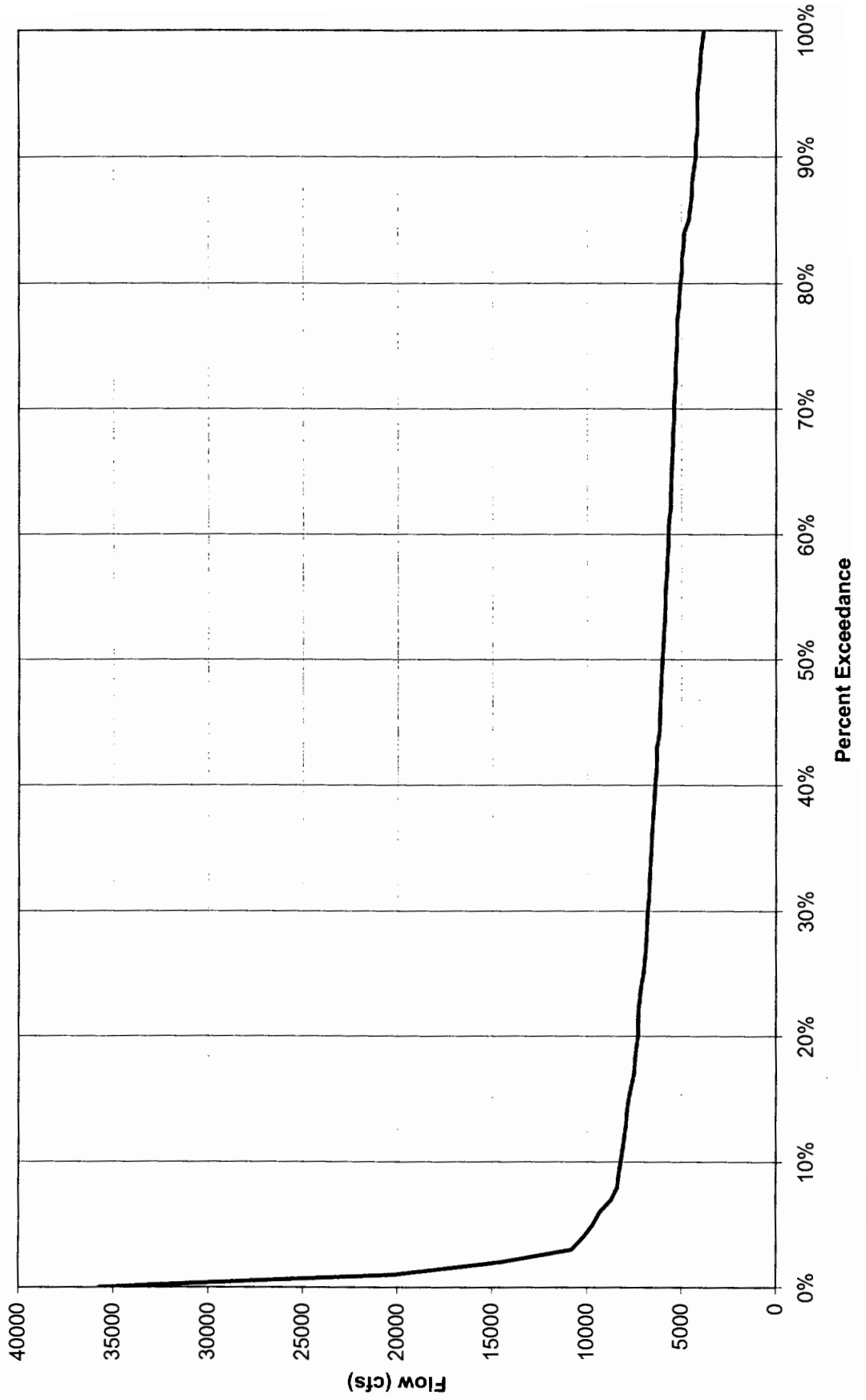

**Butler Creek August Flow Duration Curve
1/1/1992 - 4/2/2002**

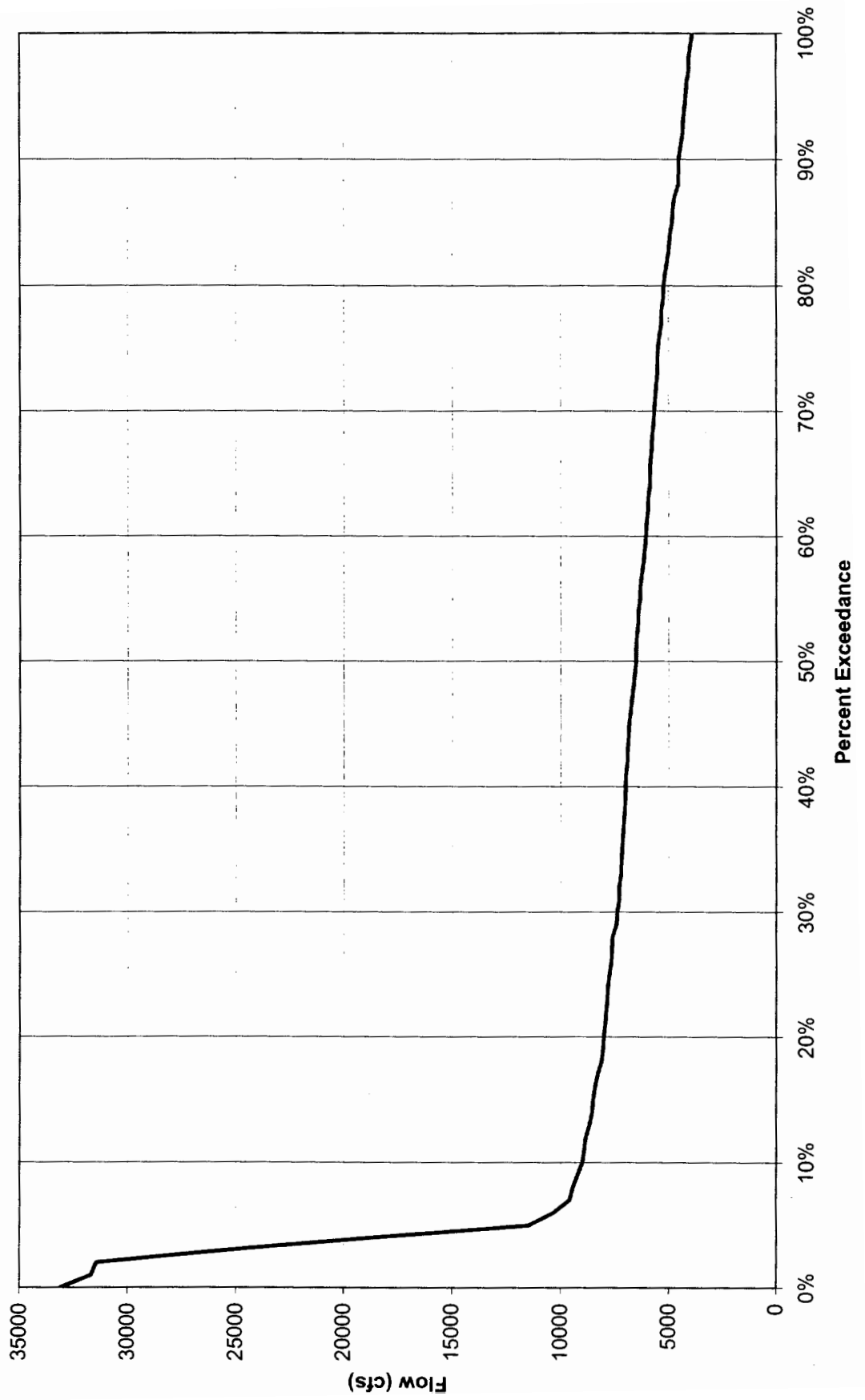

Butler Creek September Flow Duration Curve
1/1/1992 - 4/2/2002

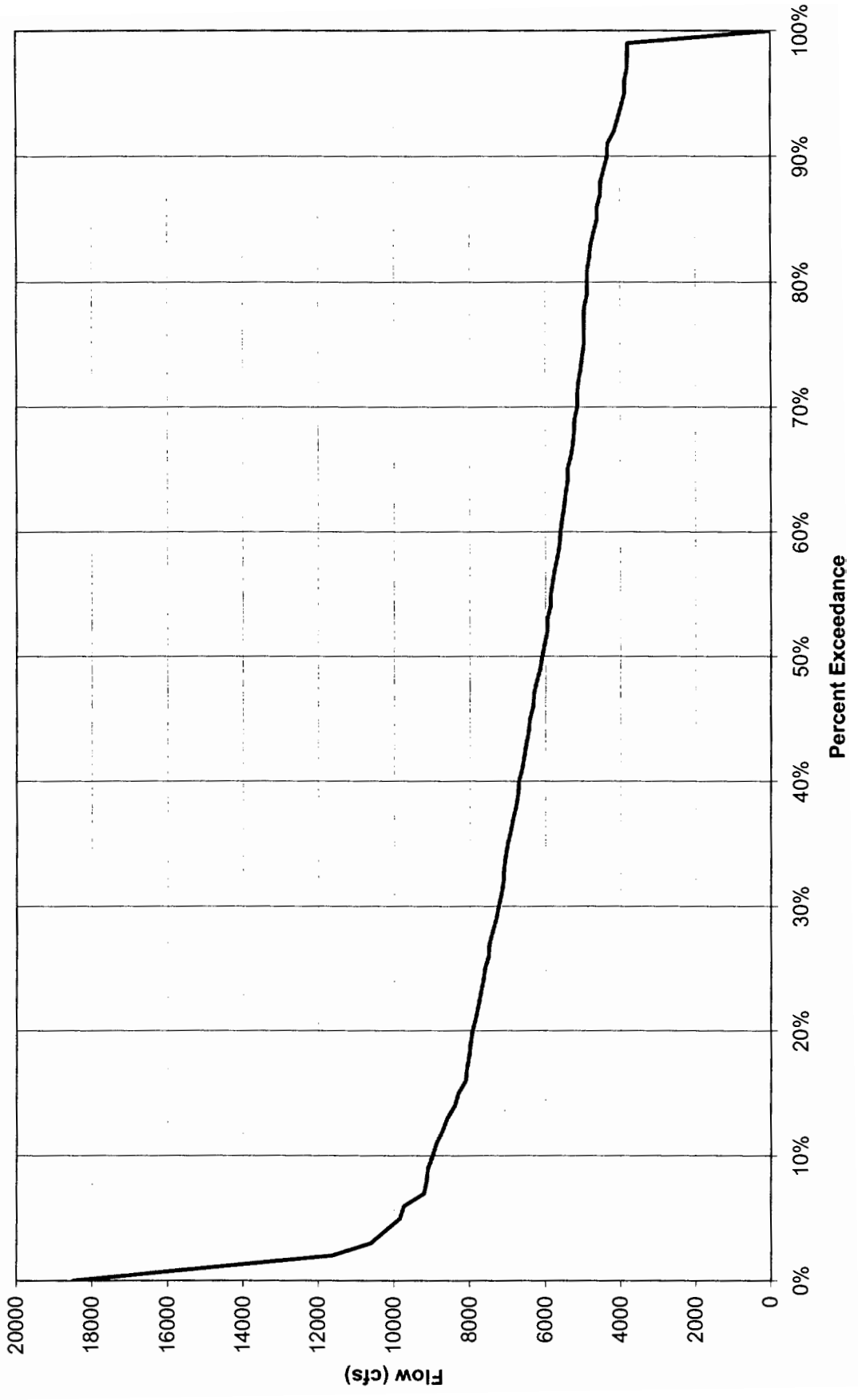

**Butler Creek October Flow Duration Curve
1/1/1992 - 4/2/2002**

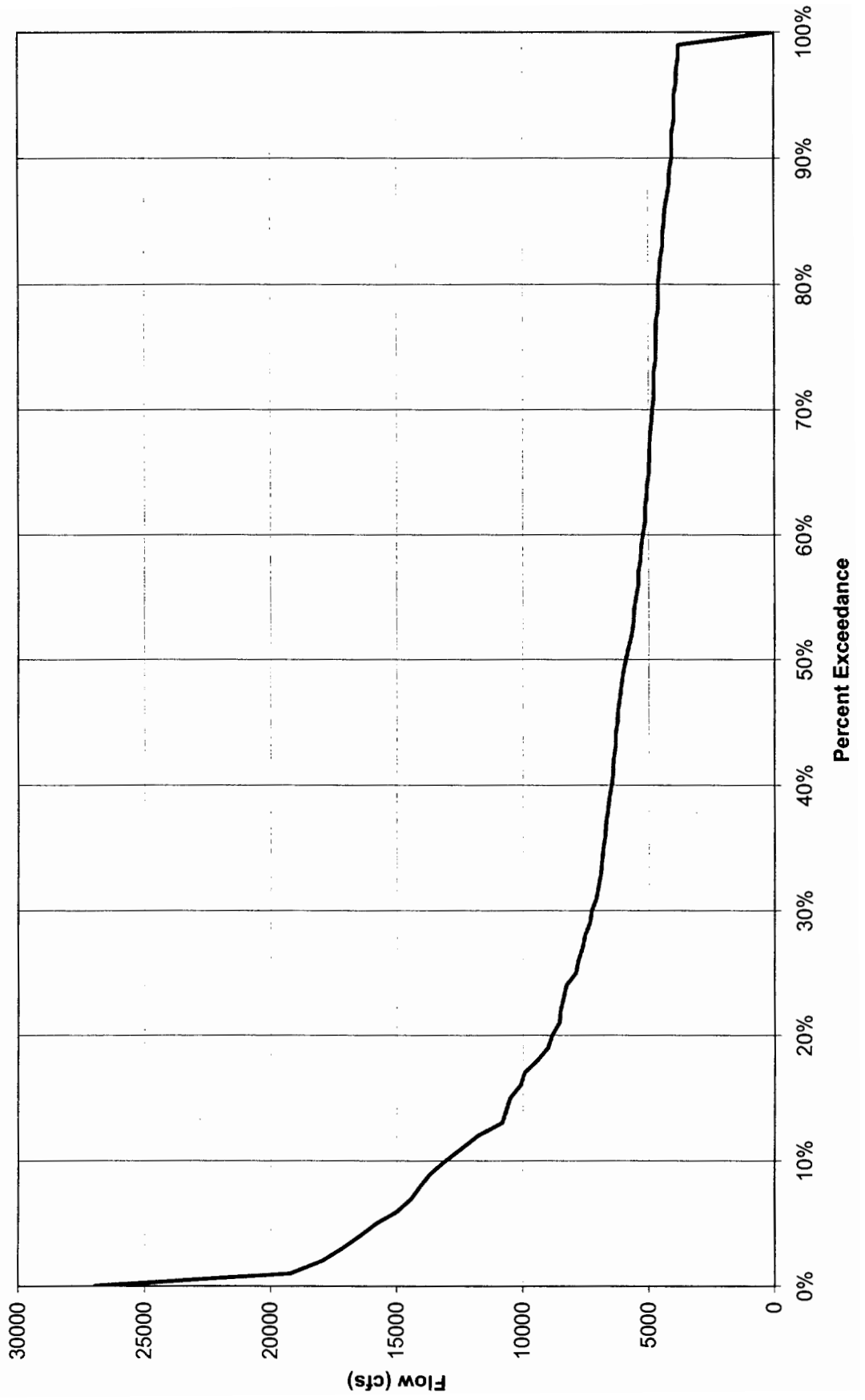

Butler Creek November Flow Duration Curve
1/1/1992 - 4/2/2002

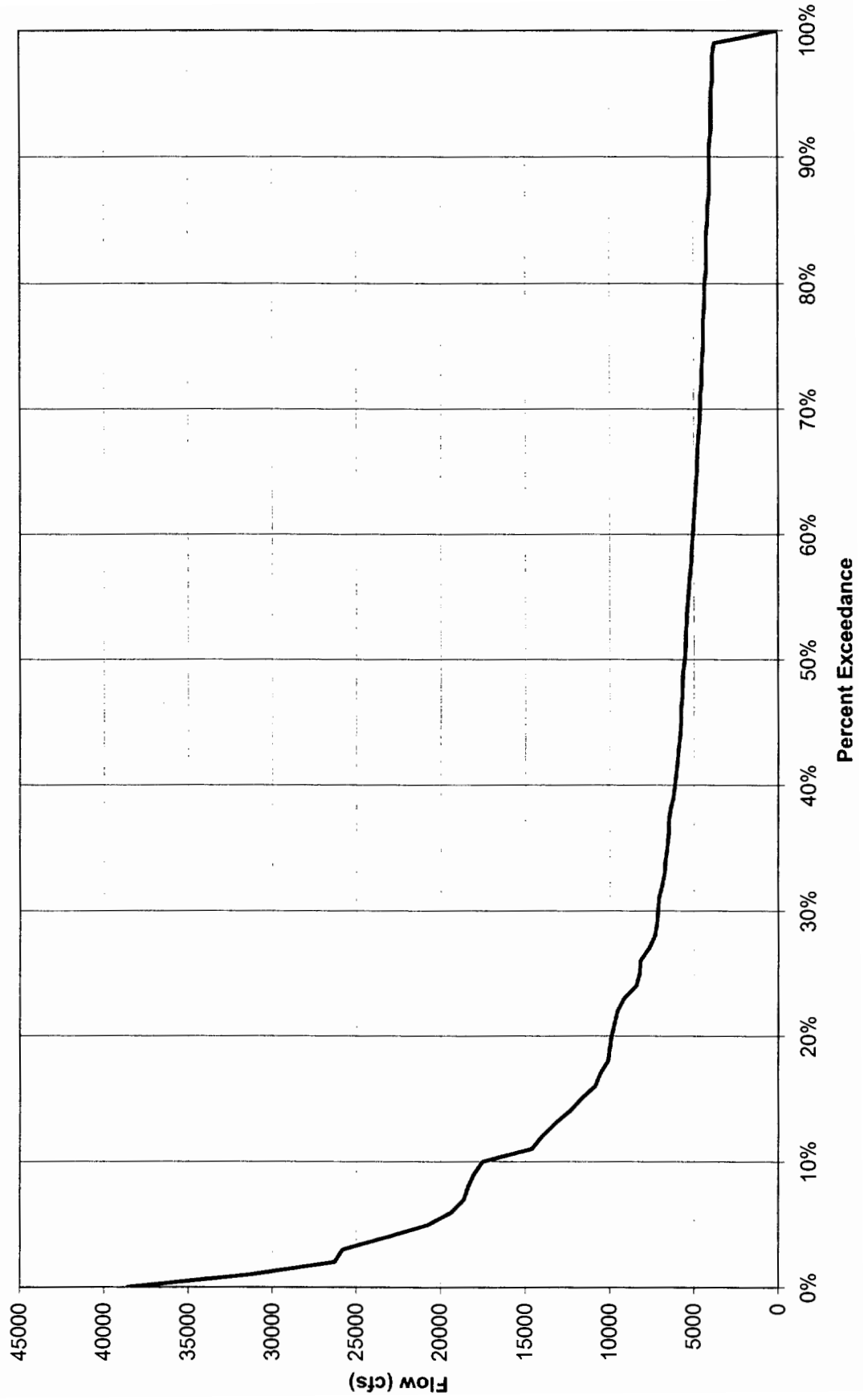

Butler Creek December Flow Duration Curve
1/1/1992 - 4/2/2002

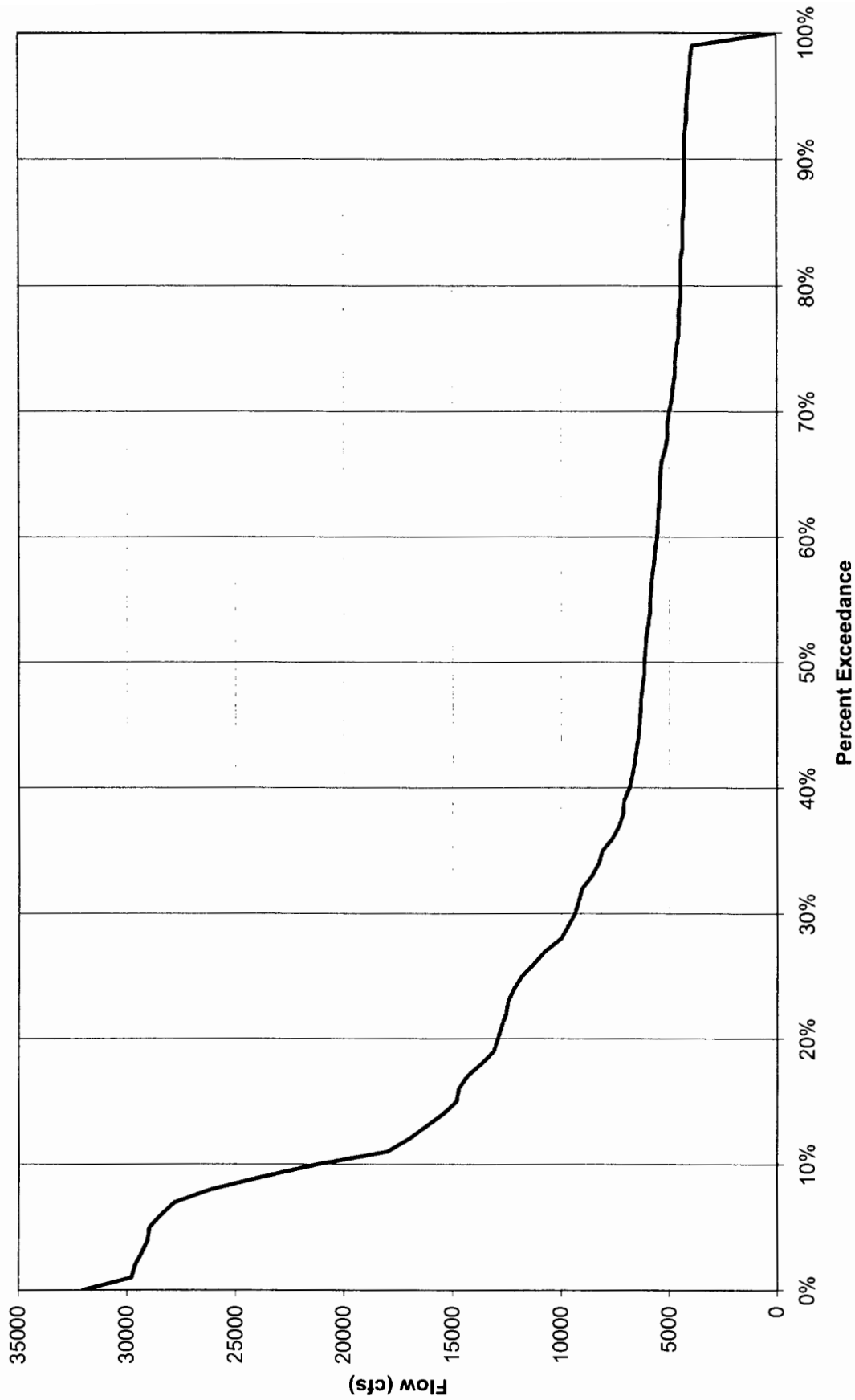

Appendix F - Meeting Minutes

NEW SAVANNAH BLUFF LOCK & DAM FISHWAY CONSULTATION MEETING

FINAL MINUTES

**May 21, 2002, 1:30-4:30 p.m.
Charleston, SC**

1. Introduction of Meeting Participants

Bill Bailey provided opening remarks and all parties provided introductions. (See attached list of Participants)

2. Review Agenda and Purpose of Meeting

Bill Bailey provided an overview of the agenda and meeting purpose. (See Attached Agenda)

3. Review Current Schedule For Fishway Design and Construction

Bill Lynch provided an overview of the current schedule of events, including concurrent efforts to repair the lock and dam structures (by others), and current project funding status. In the near term, the fishway design efforts will focus on narrowing down the field of potential design options to three preferred fishway options during the next month. At that point, a second agency consultation meeting will be scheduled (last week of June) to review and confirm the process/logic followed to arrive at the three preferred fishway design options. Resource agency participants will be expected to reach consensus on the final preferred fishway option at that meeting. The selected final preferred option will then be advanced to the 35% design level and cost estimate over the summer. The 35% design and cost estimate will then be used to secure funding for final design and construction phases of the project.

Resource agency personnel indicated concern with the schedule, that it may not be realistic to expect agencies to reach consensus on the final fishway preferred design at the June meeting. They indicated a commitment to try to meet the schedule, but suggested that a two week review period following the June meeting would be better.

4. Review Fishway Design Efforts to Date and Resource Agency Involvement

Bill Bailey provided an overview of the subject design efforts completed to date, complete with resource agency involvement. He noted that this meeting was in response to resource agency comments on the 216 Report Addendum, indicating serious concerns with the fishway design proposed in the 216 Report, and requesting a new review of all potential fishway design alternatives.

Steve Gilbert said he wanted to compliment the Corps on their efforts to involve the resource agencies early in the process, and that it was in everyone's best interest to design the best possible fish passage for the site.

5. Confirmation of Resource Agency Design Criteria

Prioritization of Target Species

- Steve Gilbert noted that there is an "Anadromous Fish Restoration Plan" for the Savannah River that has been accepted by FERC as a "Comprehensive Plan". He said it is a consensus document, not a full restoration plan. Steve Gilbert will send a copy of this plan to Steve Arnold
- Agencies indicated that some of the previously submitted design criteria have changed.
- It was emphasized that NSBL&D was the first of several dams in a series on the Savannah River and that the entire fish community of the river is influenced by this dam. All parties expressed a willingness and desire to maintain open lines of communication, and furthermore, to develop the best fish passage system possible.
- The design "target species" were discussed. Jeff Isely listed the species of interest he had collected in the project vicinity during recent years. After much discussion, it was agreed that if the following species/groups were targeted for passage, most species of concern would be benefited:

-Shortnose and Atlantic Sturgeon (information on lake or white sturgeon may be helpful). Boyd Kynard criteria for Atlantic sturgeon (5-8 ft long) is a minimum opening size of 3 ft wide by 2 ft deep.

-American Shad (surrogate for all Alosids including blueback herring and hickory shad).

-Robust Redhorse (surrogate for all sucker species).

-Striped Bass (spawning and thermal refuge movements).

-American eel (S. Gilbert noted this species will go through most fishways when migrating upstream, and would have little difficulty passing through a vertical slot ladder, nature-like bypass, or a rock ramp weir).

- The number of each species that need to be passed remains undefined.
- Jeff Isely commented that he has both shortnose sturgeon and robust redhorse tagged with radio transmitters. Although he will likely collect data useful in fishway design, the information will not be available in time for this phase of design.

- The Agencies did not want to prioritize, but expressed a desire to pass all species.

Hydraulic Design Criteria

- Steve Gilbert provided two hand outs on hydraulic design parameters. One was for a “nature-like bypass channel” and the other was the design memo from Ben Rizzo dated 10/25/00 (submitted as part of the 216 Report Addendum comments from USFWS on 5/21/01).
- The Agencies expressed interest in a nature-like bypass channel, having a slope of 0.5 percent (3,000 feet or longer) and designed to pass all species. Since a natural channel would require the purchase of additional lands, it was recognized that this was a difficult hurdle to overcome. The agencies indicated that the “natural channel” concept was experimental in this region but noted the design had been successfully constructed and tested many times in Europe. The agencies remained interested in pursuing this design alternative
- A target hydraulic design basis for attraction flow, equal to around 5 percent of mean flow, was provided. This was estimated at approximately 600 cfs for spawning season (Feb. through June), or lower at other times of the year. Only a portion of the attraction flow needs to travel through the fishway, the remainder may be delivered directly to the fishway entrance as attraction flow.
- It was agreed that 20,000 cfs was the maximum river discharge for fishway design.
- The Agencies indicated that a Rock Ramp could be constructed on a slope steeper than 0.5 percent. It was noted that one advantage of this design was that a wide variety of hydraulic conditions are provided at different locations within the Rock Ramp structure, offering suitable passage conditions (both upstream and downstream) to a wide variety of species.
- The agencies indicated that they would like to see the fishway entrance and exit located as close to the dam structure as possible.
- The 2000 study performed by Rizzo was primarily directed at Shad and did not include Stripped Bass, robust redhorse, or Sturgeon. It was suggested that a submerged orifice large enough to pass a sturgeon (at least a 5-ft Atlantic sturgeon) would be needed in fishway baffles. However, submerged orifice designs caused problems for shad passage.
- Steve Gilbert suggested contacting Piotr Parasiewicz (Cornell Univ.), Boyd Kynard (Conte Lab, USGS), and Ben Rizzo as good information resources for fishway design criteria.

Operational Criteria

- The spawning season was determined to be February to June, but there is also a fall run of Atlantic sturgeon. Agencies indicated they would prefer year-round fishway operation.
- The Agencies expressed a desire to provide both continuous upstream and downstream passage.
- The Agencies also indicated that as long as there are no turbines, the fish (with exception to adult sturgeon and maybe striped bass) would negotiate downstream passage through current gate operations. A rock ramp would also provide downstream passage for all species, providing the entrance was properly designed to attract downstream migrating fish.
- A question regarding adult sturgeon downstream passage, was directed at the gate sill elevation and the river bottom elevation immediately upstream of the dam. Would the elevation difference create a vertical lip that might function as a barrier to downstream sturgeon movement ?
- After much discussion, the agencies agreed that they just did not have good data regarding downstream movement. They agreed that with the possible exception of sturgeon and striped bass, the dam gates would serve as the primary downstream passage route. While downstream movement needed to be a design consideration, the fishway design effort should concentrate primarily on upstream movement.

O&M Considerations

- Operation and maintenance of the system was discussed, including the transfer to the city of North Augusta. All parties agreed that a passive system with minimal annual O&M cost and labor requirements would most likely be the most attractive.
- In the future, lock operations will be infrequent and therefore should not be considered as the primary bypass system. The poor structural condition of the downstream lock wall was also noted as a reason to stay away from that location. Georgia DNR is also concerned about loss of shore based fishing access if the fishway were located in the lock or in gate #1.
- When looking at downstream flows, one should only consider flows since Thurman was placed into service in 1957.

6. Preliminary Discussion of Design Options

- The last hour was dedicated to a review of current alternatives developed to date by Jon Truebe, including a rock ramp, lock passage via attraction flows and vertical slot fishway.

- Doug Cook suggested a fish lift should also be considered. While all agreed a lift is one of the most versatile fishways for a diverse mix of species, it also requires the most labor, maintenance and O&M commitment. It was agreed upon that without a Federal commitment to operate the fish lift, this alternative was not very attractive.
- Steve Gilbert expressed a desire for a passive system. He also indicated that he would like for the Corps to be responsible for monitoring, effectiveness testing and project enhancements prior to turning over operations and maintenance to the city of North Augusta. Therefore dollars must be included in the budget for:
 - A) Construction and short term modifications.
 - B) Defined term monitoring of effectiveness.
 - C) Defined term operations and maintenance.

With B & C determined to be approximately 2 years.

- It was also agreed that a fish lift, pumping, and locking were not practical primarily due to labor and O&M commitments.

Next Meeting

The next meeting was tentatively schedule for 10:00 am Thursday, June 27 (subsequently changed to June 26) to be held in Savannah. A preliminary report will be provided to the agencies during the week of June 17 – 23 (as earliest as possible). DE&S will provide these reports to Bill Bailey. Bill with then forward to the agencies. Steve Gilbert will provide a list of report recipients to Bill Bailey for direct mail (Steve will be out of the office).

	CO.	PHONE
JON TRUBE	LEI	603-539-1930
Ren Grady	Frametone ANP-DEIS	704-382-2787
Steve Arnold	Frametone ANP-DEIS	(202) 775-4495
Steve Gilmore	USFWS	(843) 727-1707 X12
Ted Wain	GA-DNR WRD	(912) 729-2112
Paul Lyons	COE Sav. Dist	(912) 652-5276
William Bailey	COE Sav. Dist	912-652-5781
Maurice James	COE Mobile Dist	251-690-3109
Tia Barrett	GA - DNR	912 727 2112
Ramon Martin	GA - DNR	912 727-2112
Jeff Dooly	SC Compliance	864-656-1265
Mark Collins	SC DNR	843-762-5008
Ray Cooke	SC DNR	843-825-3387
Ed Bettross	GADNR	706-595-1619

AGENDA
NEW SAVANNAH BLUFF LOCK & DAM
FISHWAY CONSULTATION MEETING
May 21, 2002, 1:30-4:30 p.m.

1. Introduction of Meeting Participants
2. Review Agenda and Purpose of Meeting
3. Review Current Schedule For Fishway Design and Construction
4. Review Fishway Design Efforts to Date and Resource Agency Involvement
5. Confirmation of Resource Agency Design Criteria

(Note to Resource Agency Attendees – It is our intention to leave the meeting with the following criteria resolved so we can proceed with design work. Please be prepared to provide this information at the meeting.)

- Prioritization of Target Species
 - Shortnose Sturgeon
 - American Shad
 - Robust Redhorse
 - Other Species
 - Hydraulic Criteria
 - Velocity Criteria
 - Depth Criteria
 - Attraction Flow Considerations
 - Operational Range (River Discharge)
 - Other Hydraulic Considerations
 - Operational Criteria
 - Upstream Passage Season of Operation (by species)
 - Downstream Passage Season of Operation (by species)
 - Year around operation to allow continuous fish movement
 - Operation and Maintenance Considerations
 - Low requirement for manpower vs. daily requirement
 - Certainty of operation (any designs limited by river discharge)
 - Certainty of operation (any designs limited by operation of lock)
 - Coordination with Lock Operation
6. Preliminary Discussion of Design Options
 - Location Preferences
 - Permitting Considerations
 - Initial Screening of fishway types (lift, lock, ladders, rock weir/natural channel/European designs, boat lock passage, gate passage, piggyback gate, etc....)
 - Maintenance requirements after a flood
 - Need for and ease of maintenance
 - Possibility of fishway alignment changing in response to high flows
 - Performance during a drought
 7. Open Discussion of Fishway Design Preferences.

NEW SAVANNAH BLUFF LOCK & DAM FISHWAY CONSULTATION MEETING

**June 26, 2002
10:00 a.m.-3:00 p.m.**

From 10:00 am to 3:00 pm on Wednesday, June 26, 2002, participants representing Framatome ANP DE&S (FDE&S), the Corps of Engineers (COE) and various agencies met at the COE Savannah District Office to discuss the second interim draft report of the fish passageway feasibility effort. The purpose of the meeting was to review actions to date, address outstanding configuration issues and attempt to narrow the field to one preferred alternative. Listed below is a summary of the items discussed. The list of attendees is attached to meeting minutes.

1. Opening and Introductions

Bill Bailey passed out the meeting agenda and introductions were made.

2. Summary of the May 21st Meeting

Design parameters were established for preparing and evaluating alternatives for the Fishway at New Savannah Bluff Lock and Dam. Targeted species for fish passage and options were identified and discussed. Sketches of preliminary designs were also introduced.

3. Preliminary Discussion Including Design Criteria

- Steve Arnold (Framatome/Duke) led a discussion of the draft Evaluation Report that had been provided previously.
- The previous meeting minutes were recognized as well as comments received by all parties. The minutes will be revised to reflect any and all comments prior to the next report submittal.
- Steve briefly discussed the project background, the 216 report and overall study objectives.
- The previous study effort (rock gabion design) was discussed which drew various comments from the Agencies and resulted in the study effort currently being executed by FDE&S.
- The design criteria presented within the report was addressed in detail as well as comments received from the agencies. All comments received will be incorporated into the final report.
- All of the alternative fish passage schemes were discussed included FDE&S' narrowing the field to 3 alternatives. Mr. Brownell who was absent at the previous meeting has yet to submit comments, but does plan to do so prior to July 9. Early in this meeting, Mr. Brownell indicated that he would like to see the natural fish channel remain a candidate for consideration. Mr. Bill Lynch then stated that this alternative

would require additional land from an unwilling land owner. Furthermore, should this alternative be selected, the process could be delayed for an extended period of time. In any event, Steve Arnold indicated that the previously issued meeting minutes would be revised to reflect these comments to properly reflect the flow of information and paper trails.

- Steve Gilbert indicated that he was unable to narrow the field to one alternative and would like to carry 2 or 3 alternatives to a 35% design effort. Bill Lynch then responded that the COE has a narrow window of opportunity to carry the project forward and should the decision of a preferred alternative be delayed, there was chance the entire project could be delayed. In any event, it was mutual agreed upon that all was committed to installing the best possible option.
- Steve Arnold stated that headwater variation is not a problem at this location and that minimizing O & M costs will be a high priority when choosing one of the alternatives.
- Steve briefly summarized Section 4 in the report and there was some discussion regarding the protocol for gate operations particularly as it relates to the potential future downstream movement of fish. After some discussion, it was clarified that Gates 2, 3 and 4 (underflow gates) were raised and lowered as needed to control headwater elevation and meet the minimum bypass flow requirements of 3600 cfs. Gates 1 and 5 are normally operated as overflow gates and only pulled (completely out of the flow path) when flows reach approximately 20,000 cfs. There were questions regarding the COE's ability to effectively control headwater elevation/minimum flow by operating one gate as opposed to 3, thereby creating a more effective passage way for fish moving down stream. Maurice James stated that he would look into this possibility. The COE indicated they have no daily record of gate openings and are often operated several times a day.
- There was some question regarding the staff gage vs. NGVD correlation value. It was later determine that this figure was 100.58 as opposed to 101.0 as previously provided by the COE.
- Steve Arnold then went over the "target species". The following targeted species for fishway passage were discussed: American Shad, Shortnose Sturgeon, Robust Redhorse, Stripers and American Eel. It was stated that the Shortnose Sturgeons behavior limits alternatives to a 5% grade and Steve Arnold added that the swimming performances of various species affect the success of alternative designs for a fish passage structure.
- There was some discussion to document the work to date at the Cape Fear Fish Bypass System, which is scheduled for construction release in approximately 40 days. New plans are expected to be issued as a result of last weeks meetings.
- Steve discussed the need for a fish passageway system that could accommodate a wide variety of hydraulic design conditions (flow, speed, depth, etc.). He stated that there is not a downstream mortality problem here, as downstream passage is occurring through the gates, but that upstream passage is the primary concern. Steve

Gilbert stated that he is concerned about benthic-oriented species and their downstream passage.

- There was some discussion regarding recent actions were various parties have explored the possibility of installing a hydroelectric station near the facility. Bill Lynch stated that the COE's mandate is to proceed with the assumption that no hydroelectric power station will be located at the site. Should a hydro station be realized in the future, then proper consideration would need to be given to the passage of fish within the design of this new power station. In any event, future hydroelectric power station at this site is not a current design consideration.
- After some discussion, it was determined that the primary focus of this design effort would be to concentrate on the upstream movement of fish. However, the downstream movement of fish should also be a design consideration. Steve Arnold agreed to amend the previous meeting minutes to reflect this agency comment. Steve Gilbert then stated that he would like the downstream passage be addressed a bit more in the report.
- There was some discussion regarding the need for 1 ft. contours at the river/structure interface particularly as it relates to the ability of fish to negotiate through the gate openings both upstream and downstream. Maurice James agreed to look into this to determine what information was available.
- Doug Cooke asked if the thickness of the flow over the outside gates during drought situations is adequate for the passage of the surface-oriented shad. Maurice James responded that this thickness is one to two feet. It was stated that the basis for this design is a design flow of 3,600 to 20,000 cfs. There was continued discussion regarding the gate operations. Steve Arnold agreed to add a statement to the report that the design flow range for the bypass system would be between 3,600 cfs and 20,000 cfs. Furthermore, 600 cfs would be considered the maximum design attraction flow. Steve Gilbert indicated that the attraction flow values were acceptable.
- Steve Arnold stated that keeping the entrance and exit as close to the dam as possible is important.
- It was added that Striped bass congregate near gates three and four, while shad congregate near five.
- The phrase "bank overtopping" would be removed from page 17 of the report.
- Steve Gilbert indicated that maybe gate manipulations can be adjusted to best enhance performance of the fish bypass system.
- Several participants indicated that they would like to further study the location and configuration of the "Horseshoe" intakes.
- There was some discussion regarding the capacity of the fish bypass system. Steve Gilbert indicated that 50 fish per acre would be a good assumption.
- The bypass system entrance and exit was discussed. It was mutual that these structures should be as close to the dam as possible.

- Water Control – Steve Arnold is to remove the 16,000 cfs reference and leave “up to 20,000 cfs”.
- Mr. Brownell asked that design consideration be given to future monitoring. It was further stated that this should not be a considerable design effort. The agencies just did not want to miss an opportunity to consider future monitoring at this stage in project development.
- Stephania Bolden asked if debris is a problem. The issue of debris was discussed. Apparently, debris tends to collect at the three center gates, but not at gates 1 and 5. Maurice James responded that during periods of heavy flow, it is not unusual to open gates and pass debris once per week.
- Steve Gilbert asked about access. The response was that access would be provided for the agencies. However, there would be no general public access in the area of the fish bypass system.
- The design depth of flow was discussed. There was discussion that 3 feet would be acceptable. Mr. Brownell indicated that 5 feet would be much better. This will most certainly be the subject of additional comments due no later than July 9.

4. Evaluation of Alternatives

Mr. Jon Truebe reviewed in detail the alternative matrix presented in the report.

A matrix containing twelve fish passage alternatives was passed out. Nine were eliminated from further consideration because of the following reasons stated in parenthesis: Pool and Weir/Gabion (Difficulty of construction and Need for supplemental flow volumes), Full River Rock Ramp (No control of pool elevation), European/Natural Channel (additional real estate required), Denil Fish Ladder (not adequate to pass large sturgeons), Pool and Weir Fish Ladder (headwater sensitive, needs additional gates and multiple species problem), Mechanically Generated Currents in the Navigation Lock (High operational requirements), Gravity Flow Gate Manipulation in the Navigation Lock (High operational requirements), Fish Lift/Fish Lock (High operational requirements and High O&M costs) and Fish Pump (High operational requirements and High O&M costs). This elimination left three alternatives (in no particular order):

- Rock Ramp Gate No. 5
- Rock Ramp Horseshoe SC Side
- Vertical Slot Fish Ladder

The discussion then centered around these three alternatives. Steve Gilbert stated that he likes the in-river access of “Rock Ramp Gate No. 5” that “Rock Ramp Horseshoe SC Side” doesn’t provide. He felt this would aid upstream passage of fish. He also expressed concerns about the flows within the Horseshoe. It was stated that the Horseshoe allows the full 600 cfs to be carried downstream. Doug Cooke asked if the Horseshoe radius will cause a flow problem and Maurice James replied that the radius is sufficient. Several attendees expressed concerns about upstream passage for the Horseshoe and flaring at the entrances

was discussed. Steve Gilbert and Prescott Brownell stated that the "Vertical Slot" is their third choice with the other two being preferred. It was added that USFWS will contact Luther Aadlund for his opinion of the Horseshoe design. An attendee asked if the removal of Gate No. 5 could cause flooding. Maurice James replied that in 1934, when the Lock and Dam was built, there were no large dams upstream. He stated that this indicates no flooding should result from this gate removal. The Corps will check this to be sure. Prescott Brownell stated that the Horseshoe design may be better than the Gate No. 5 design for sturgeon passage. Maurice James stated that Gates 1 and 5 can be operated to control the thickness of the overflow. Steve Gilbert asked about the cost of the three options and Bill Lynch added that they are comparable. Bill Bailey stated that either the Corps or South Carolina could ask for an easement for road access if the Horseshoe design is selected. Steve Arnold asked which alternative the attendees preferred. Steve Gilbert replied that Gate No. 5 and the Horseshoe designs are equally appealing to him, with the Horseshoe design providing better downstream passage. Stephania Bolden wants Piotr Parasiewicz and Boyd Kynard to review the Gate No. 5 and Horseshoe alternatives and give recommendations. Maurice James favors the Horseshoe design as it stays away from the Lock and Dam structure. The structural engineers are somewhat concerned about additional weight being placed on the supports for the dam and excessive vibrations that some construction techniques could produce. Driving sheetpiles is of some concern to them. He added that for the Gate No. 5 option, a sheet pile cutoff wall would have to be placed and if the existing pilings under the dam are at an angle, this could be a problem. Stephania Bolden shared that she would like to have a minimum depth of water in the Horseshoe design of five feet throughout and Steve Gilbert added that a minimum three feet width is needed for sturgeon pectoral fin passage. (These criteria would also apply to the Gate No. 5 design.) It was stated that gates one and five are either completely open or completely closed and in the case of the Horseshoe design, these gates would be open and the upper pool would fluctuate little. Steve Gilbert stated that the gate operation routine will be specified by the Corps and required of the new owner. Joe Hoke added that the gate operation will be done remotely.

The natural channel was again a topic of discussion. It was agreed that a statement would be included in the report documenting that additional land would be required from an unwilling land owner and the other text would be removed from the report.

Steve Gilbert also indicated that he would like to recognize (in the report) that the lock can be used in the future also as a means of fish bypass.

Steve Gilbert requested the Corps evaluate potential modifications to the training wall located along the SC shore about 10 miles upstream of the dam. He is concerned that sturgeon could become trapped by the upper end of the training wall.

5. Conclusion

Six "Action Items" were identified:

1. Maurice James will look at the upstream bathymetry survey by Friday. This info will allow an assessment of the siltation upstream of the dam and any vertical steps that

would be encountered by benthic-oriented species attempting downstream passage. Savannah District will pass this info along to the agencies.

2. The Corps will develop hydraulic information on gate openings and velocities to allow determinations to be made on their adequacy for downstream passage. Savannah District will pass this info along to the agencies.
3. The Corps will distribute the Draft Report to Luther Aadlund for review (Done 26 June). The Corps had previously sent the report to Ben Rizzo and Piotr Parasiewicz. The USFWS will contact these individuals.
4. The Corps will distribute the Draft Report to Alan Blott (Done 27 June) and Boyd Kynard (Done 1 July) for review. The NMFS will contact them.
5. Comments on the preferred alternative are due to Savannah District (Bill Bailey) by 9 July from the two States and Federal agencies.
6. David Allen requested a copy of either the Draft Evaluation Report (if one is available) or the revised report. (Since we do not have any extra copies of the Draft, we will provide him with a copy of the revised report.)

Appendix G Correspondence

Appendix G.1 October 25, 2000 Rizzo Memo to Gilbert

DEPARTMENT OF THE INTERIOR
ENGINEERING FIELD OFFICE
SUITE 612, ONE GATEWAY CENTER
NEWTON CORNER, MA 02458-2802
TEL. (617) 244 1368
FAX (617) 527 6848

October 25, 2000

To: Steve Gilbert, (ES)
Charleston SCFO

From: Ben Rizzo, FWS Engineering Consultant
Newton Corner, MA



Subject: Suggestions for Improving Fish Passage at New Savannah Bluff Navigation Lock on Savannah River below Augusta, GA

Reference is made to your Sept 8/00 request for technical assistance in developing modifications to improve upstream fish passage at the existing navigation lock at the New Savannah Bluff Lock and Dam (NSBLD) Project on the Savannah River near Augusta, GA. This project was constructed by the Corps Savannah District.

Jeff Morris of the Corps Savannah District Planning Office forwarded our office some project plans in June/00 (at your request) to assist in our project review. We also received some project photos from Jeff in Oct/00 and additional project design and hydraulic data from Joe Hoke and John Hager of the Corps Savannah District. We understand the Corps is conducting a study regarding rehabilitation/decommissioning options for this project and has included as an option an agency recommended fish bypass channel at the SC side of the spillway to improve fish passage. A preliminary report on this study will be issued for agency review later this year.

The NSBLD is located at RM 187 on the Savannah River approx 12 miles downstream from the City of Augusta, Georgia. It is the lowermost barrier on the Savannah River which is the boundary between GA and SC. The average river discharge at this site is approx 9,550 cfs. The project consists of a five bay spillway (approx 350 ft long) spanning the river between concrete piers. A navigation lock (56' wide x 360 ft long lock chamber) is located on the Georgia shore. The spillway has two fixed crest steel gates at each end (each approx 60' wide) and three steel lift gates (each approx 60' wide) in the interior bays. The normal maximum head at the spillway and lock lift is approx 17 feet during low river flows (4,000 cfs). During high spring flows (above 25,000 cfs) the head drop at the drowned out spillway with raised interior gates can be as little as 6 inches. The headpond is normally kept near elev 114 - 115 by spillway gate manipulation, to facilitate a navigation channel upstream.

Existing Fish Passage

Currently upstream migrants pass this project by the periodic operation of the navigation lock during the spring migration season (March to May), or by passing over (or under) the spillway gates

during periods of higher than normal spring flows--- when there is very little drop at the spillway due to tailwater levels rising. Jeff Morris advised the city of Augusta is responsible for lock operations for fish passage and is supposed to follow a MOA signed in 1995 between the City of Augusta and Corps. It is our understanding (through Jeff Morris), the City has been lax in providing lock operations for fish passage in recent years and the lock was not in operation for most of this year due to need for lock repairs and safety issues.

River Flows During Spring Migration Period

We reviewed the tailwater and headwater data provided by the Corps and USGS and records of flow from 1952 to 1998 at theUSGS Station at the project site (Savannah River at Augusta, GA, DA = 7,508 sq miles) Our review indicates the following mean flows for the spring migration period:

<u>Month</u>	<u>Mean Flow</u>	<u>Est HW Level</u>	<u>Est TW Level</u>	<u>Approx Head</u>
Feb	12,420 cfs	114.5' NVGD	106.1' NVGD	8.4 ft.
March	14,480	114.5'	108.0'	6.5 ft.
April	13,320	114.5'	107.0'	7.5 ft.
May	9,540	114.5'	103.5'	11.0 ft
June	8,360	114.5'	102.3'	12.2 ft

Estimated Mean Annual Flow = 9,550 cfs

Estimated Minimum Daily Flow during Spring Migration Period = 4,000 cfs, Tailwater level = 98.0'

Suggestions for Improving Fish Passage at NSBLD

We suggest both operational and structural improvements to enhance fish passage via the navigation lock and spillway. As an alternate to passage through the navigation lock or the proposed experimental fish bypass channel at the left bank--- we recommend a new vertical slot fishway or fish lock constructed at the left spillway abutment. (See attached conceptual plan). Following are some specific suggestions and comments:

Navigation Lock

o Operating Procedures ---We do not have details of the existing operational procedures for fish passage via the navigation lock, which may be included in the 1995 MOA between the Corps and the City of Augusta. We have outlined a suggested operation sequence (See attachment on last page-- Item #1), which includes separate lock operations for fish passage, maintaining a flow in the lock and operating partially opened lock gates during fish locking operations.

o New Side Entrance---(See Item #2 on conceptual plan)--- A new side entrance to the navigation lock wall is suggested as an appropriate measure to collect and pass migrants attracted to the spillway discharge. The navigation lock has a drain/fill culvert opening (approx 8' wide x 10' high) that runs along the length of each lock wall near the bottom. (See attached plan). This culvert and overhead pipe gallery complicate the placement of a side entrance. The side entrance channel should be opened to atmosphere (open channel flow) rather than a pressurized conduit or extension of the existing culvert system (proposed by Corps). We suggest a 6' wide x 13' high gated opening cut through the (gravity concrete) lock river wall near the downstream end of the spillway apron to facilitate collection of

migrants attracted to spillway flows. We have placed the floor of this side entrance at elev 96.0' to facilitate operation at lower river flows---this penetrates the upper portion of the drain/fill culvert. The new gate on the lock side of the new spillway entrance should be a downward opening segmented gate to provide a clear opening at low river flows and closure during lock fill operations. The pipe gallery forms the upper boundary of the side entrance. As river flows approach 16,000 cfs, the tailwater level will be at the top of the side entrance (approx El 109 ft) and we expect reduced passage efficiency at the side entrance due to submergence.

o Flow Deflector at Side Entrance---(See Item #3 on conceptual plan)--- To provide a suitable flow field at the side entrance to the navigation lock a flow deflector wall (concrete or steel) will probably be required to deflect the surface current from the spillway and enhance the jet from the spillway entrance. Field observations (and possibly a hydraulic model) will be required to determine and verify the location and design of the flow deflector..

o Fish Crowding Device We have no simple solution regarding a reliable and cost effective fish crowding device in the navigation lock. A trolley mounted screen type mechanical crowder (with hinged or hoistable crowder screen/rack) would be very expensive, would hinder navigation and require very restricted public access to the lock area during operation. We suggest a submerged high frequency sound system ("fish spooker" device in use @ St. Stephen fish lock) would be effective in moving adult alosids through the lock---this coupled with periodic seining would be our interim choices. We note there is a sill near the upper lock gate which extends approx 13' above the lock chamber floor ---this barrier may hinder the passage of shortnose sturgeon and other bottom migrants and requires further study. We suggest an inclined ramp (grating type) be considered for future installation to enhance the upstream passage of these fish---- (See Item #7 on conceptual plan). A lock fishing sequence at night with partially opened lower lock gates and attraction flow may also be required to enhance sturgeon and Am. eel passage.

Spillway Gate Passage

Passage of upstream migrants occurs over the two fixed crest (crest elev = 112.5 ft) steel spillway gates at both ends of the spillway and/or under the hoistable interior spillway gates during periods of above normal river flow. We estimate there is very limited to no passage via the spillway gates during periods of normal or below normal river flows. The fixed crest spillway gates have ogee shaped crests which results in a surface backroll in the tailpool immediately below the spillway gates (plunging flow). This flow field is notorious and not conducive to effective upstream passage especially for surface oriented anadromous alosids. The back roll probably persists even during moderately high river flows (20 to 22k cfs) when tailpool is approx 1ft above spillway crest. To assist in create streaming flow conditions (no surface backroll) which is conducive to providing effective alosid passage, we suggest a surface notch be cut in both fixed crest steel spillway gates (at the shore ends), and a floor plate installed to create a broad crested weir. We suggest a notch 2' deep x 10' long x 6' wide---(See Item #4 on conceptual plan).

New Vertical Slot Type Fishway or Fish Lift at Spillway --- (See Item # 6 on conceptual plan)

As an alternate to (or to complement) the suggested navigation lock modifications and related special operations for fish passage---- and in place of the experimental fish bypass channel at the left bank proposed by Corps---we recommend a passive new vertical slot fishway or fish lift at the left end of the spillway be considered as the primary fish passage facility at this project. The attached conceptual plan shows a layout of a vertical slot fishway (with 10' W x 10' L x 5' min depth pools x 1.3' slot width). The fishway floor slope would be 1 on 16 providing a maximum drop of 9" per pool. This design is similar to the fishway proposed at the Columbia Hydroproject on the Broad River in Columbia SC. The fishway would be self regulating and would provide effective upstream passage of target migratory

species (and possibly shortnose sturgeon), up to river flows of 35,000 cfs. A fish counting station with viewing window and possible separate public viewing facility could also be incorporated in the exit channel of the fishway. A fish elevator or fish lock could also be utilized here as an alternate upstream passage device. We would be glad to provide your office additional details of either of these schemes at a later date. A floating trash boom is recommended in the headpond, upstream of the fishway or fish lift--- to guide floating debris and vegetation away from the fishway and towards the spillway. (See Item #5 on conceptual plan).

Fish Bypass Channel

We have reviewed the preliminary plans for the proposed experimental bypass channel submitted by the Corps Savannah District (in July/00) and have grave concerns regarding the effectiveness, anticipated high maintenance, hydraulics and aesthetics of the proposed facility (over 3 acres of rock filled gabions) in providing effective upstream passage. We note the lower segment of the bypass channel will be drowned out at above normal river flows during the spring migration period. The upper control gate is a bottom opening tainter gate which is either full open or closed and not suitable as a flow regulating device---a hinged bascule gate is suggested as more appropriate for water level control. Fish bypass channels should be considered at sites which have a good mix of erosion resisting natural substrates---- and not at sites which require extensive erosion control, sheet piling, cofferdams, leakage control measures and extensive site excavation like NSBLD. It is our understanding the estimated project cost is in the \$5.5 million range for this experimental facility. We trust other passage options will be pursued.

Preliminary Cost Estimates

Following are our preliminary cost estimates for the various fish passage enhancement measures based on year 2000 price levels. Please note these estimates are preliminary and subject to change based on additional project data and design investigations.

<u>Item</u>	<u>Estimated Cost</u>
#1---Navigation Lock Operational Measures for Fish Passage	(Not Determined)
#2--- Gated Side Entrance to Navigation Lock	\$520k
#3--- Flow Deflector at Side Entrance	\$160k
#4---Notch in Fixed Crest Spillway Gates (2 @ \$20k)	\$40k
#5--Floating Trash Boom in Headpond @ Fishway	\$50k
#6--Vertical Slot Fishway at Left Bank (Alternate Fish Lift)	\$4,400k (\$3,700k)
#7--Future Ramp (Grating) at Navigation Lock Floor "Spocker"	\$290k \$180k \$ 11.2 0.1M

Please excuse our delay in responding to your request and please call if you have any questions.

B.Rizzo/file = nsbld102.000

Item #1

Suggested Locking Sequence at NSBLD Navigation Lock for Fish Passage

1. Fish collection in Lock Chamber --- Start with water level in navigation lock at tailpool level and upper miter gate closed. Close drain valve and partially open both lower lock gates (approx 12' - 15' wide) or only shore side lower lock gate (keep lower lock gate on river side in closed position). Partially open one or both fill valves to provide approx 1 fps current in lock chamber. Fish for agency designated time interval (approx 1 hour during major migration period).
2. Fill Lock Chamber --- After designated fishing interval, close the opened lower miter gate and fill lock chamber slowly to headpond level. Can keep fill valve in partially opened position to allow lock chamber to fill to headpond level. (should take approx 10 - 15 minutes to fill).
3. Fish Passage from Lock Chamber to Headpond --- After lock chamber is filled to headpond level close fill valve and open or partially open upper miter gates (can partially open upper lock gates to 12 - 15' opening to increase current and/or allow scanning sonar counting). Open drain valve to allow approx 1 fps current into lock chamber from headpond via open upper miter gate to allow fish to exit lock. Can utilize high frequency sound "spooker" to enhance anadromous alosid movement out of lock chamber or other fish crowding device. Allow 20 - 30 minutes for fish to exit lock chamber.
4. Drain Lock to Commence Fishing Cycle ---- Close upper lock gate and open drain valve slowly in increments to drain lock to tailpool level (to minimize stressing fish remaining in lock or in reach below drain ports. Repeat locking sequence #1 to 4 above.
5. New Side Entrance Operaton ---If a new gated side entrance to the navigation lock is constructed it would be opened or closed simultaneously with the lower lock gate (if tailwater levels are compatible) or can be operated alternately with the lower lock gate, as a separate fish entrance.
6. Modification of the above locking procedures may be required due to safety and operational problems.

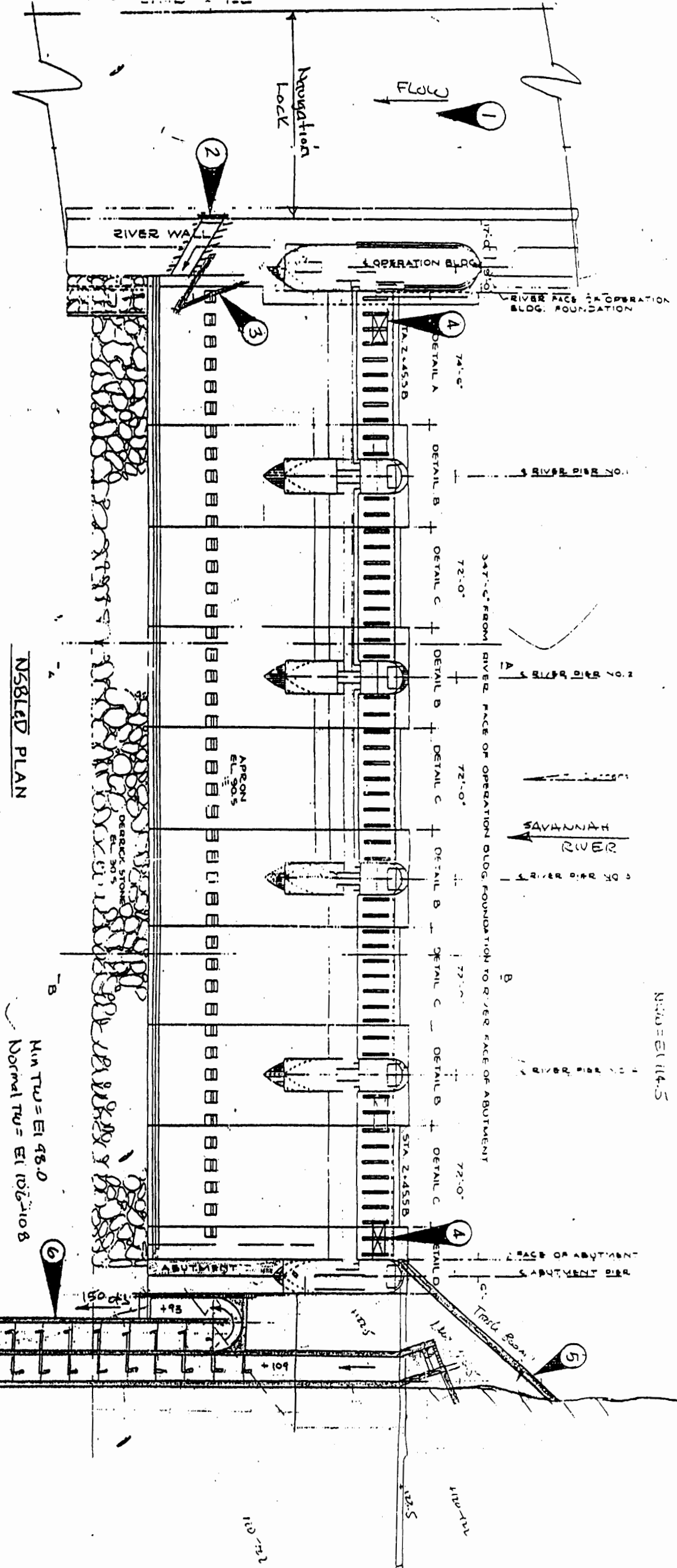

NSBLD PLAN
SCALE 1"=20'-0"

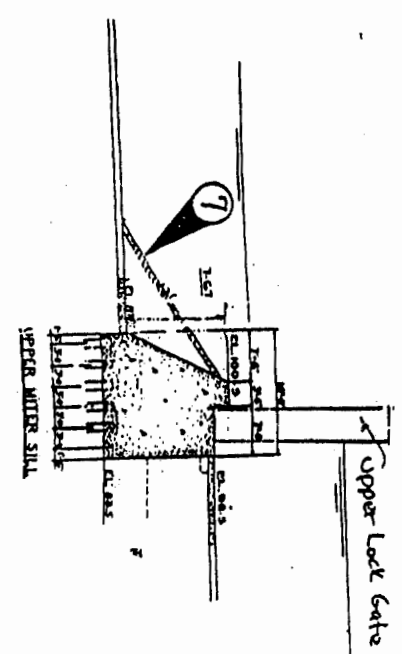
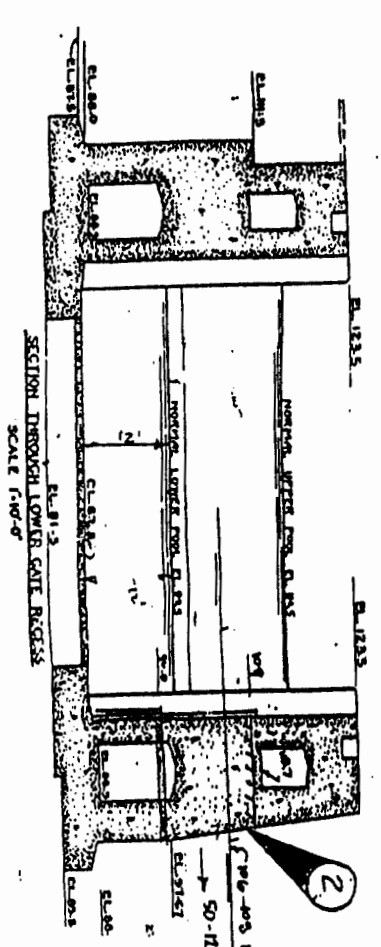

LEGEND

- ① UNDERTAKE SPECIFIC LOCK OPERATIONS FOR FISH PASSAGE.
- ② PROPOSED GATED SIDE ENTRANCE TO NAVIGATION LOCK (6'W x 13'H).
- ③ FLOW DEFLECTOR WALL MAY BE REQUIRED.
- ④ PROPOSED NOTCH IN FIXED CREST SPILLWAY GATE (10'L x 2'D x 6'W).
- ⑤ PROPOSED TRASH BOOM FOR FISHWAY.
- ⑥ PROPOSED VERTICAL SLOT FISHWAY (OR FISH LIFT) IN LIEU OF FISH BYPASS CHANNEL.
- ⑦ POSSIBLE FUTURE RAMP (GRATING) TO ENHANCE STURGEON PASSAGE.

OPTIMAL PLAN OF MEASURES TO IMPROVE FISH PASSAGE
NEW SAVANNAH BLUFF LOCK AND DAM PROJECT ON
SAVANNAH RIVER NEAR AUGUSTA, GA
BY B. RIZZO, FWS OCT 24/00

A

FRAMATOME ANP

Framatome ANP DE&S

CALCULATION GRAPH PAPER

HEADWATER CONTROL STRUCTURE• ASSUMED DESIGN CONDITIONS

1. Upstream Pond Elevation = $18.2 + 100.58 = 118.78$
(Ref. Upper Pool Duration Curve)
2. Gates in closed position with no water in canal
3. EFFECTS OF SHEET PILE neglected
4. DESIGN FOR Full Hydrostatic head & associated uplift.

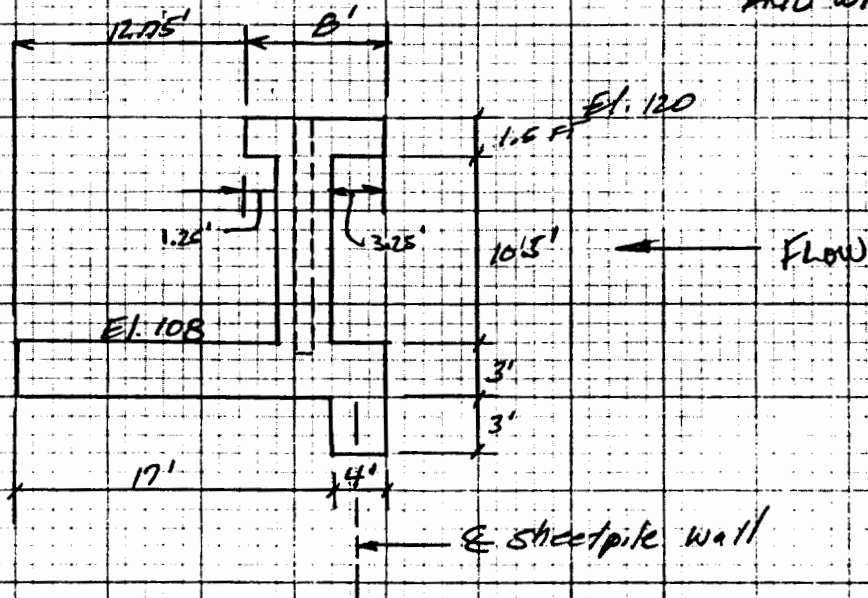
• Assume Following Configuration5. NEGLIGIBLE EMBEDDED END WALLS

CHECK FS. overturning: Σ Forces Resisting
 Σ Forces Causing

Rev.	Orig.	Date	Chkd.	Date	Client/Project:
					Subject:
					Calc. No. _____ Sht. _____ of _____

A

FRAMATOME ANP

**Framatome ANP DE&S
CALCULATION GRAPH PAPER**

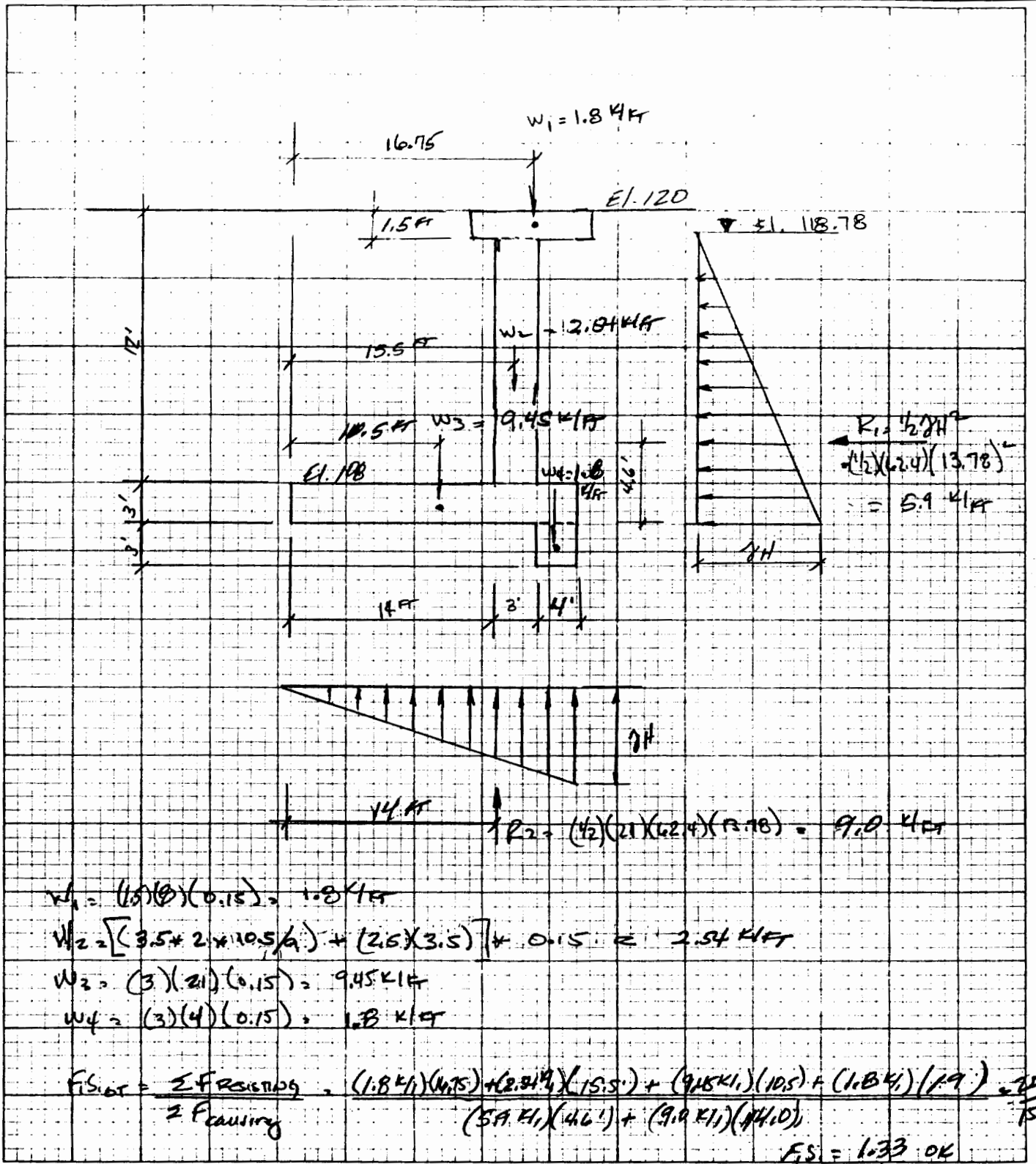

$$W_1 = (15)(0.15) = 1.8 \text{ kft}$$

$$W_2 = [(3.5 + 2 \times 10.5/6) + (2.5)(3.5)] \times 0.15 = 2.54 \text{ kft}$$

$$W_3 = (3)(21)(0.15) = 9.45 \text{ kft}$$

$$W_4 = (3)(4)(0.15) = 1.2 \text{ kft}$$

$$F.S. = \frac{\sum F_{resisting}}{\sum F_{causing}} = \frac{(1.8 \text{ kft})(16.75) + (2.54 \text{ kft})(15.5) + (9.45 \text{ kft})(10.5) + (1.2 \text{ kft})(19)}{(5.9 \text{ kft})(46') + (9.9 \text{ kft})(14.0)} = \frac{202}{153}$$

F.S. = 1.33 OK

Rev.	Orig.	Date	Chkd.	Date	Client/Project:
					Subject:
					Calc. No. _____ Sht. _____ of _____

A

FRAMATOME ANP

Framatome ANP DE&S
CALCULATION GRAPH PAPERCHECK F.S. W/IL TO SLIDINGNeglect Resisting Forces
@ ENDS OF STRUCTURE

$$F.S. = \frac{\Sigma \text{FORCES RESISTING}}{\Sigma \text{FORCES CAUSING}}$$

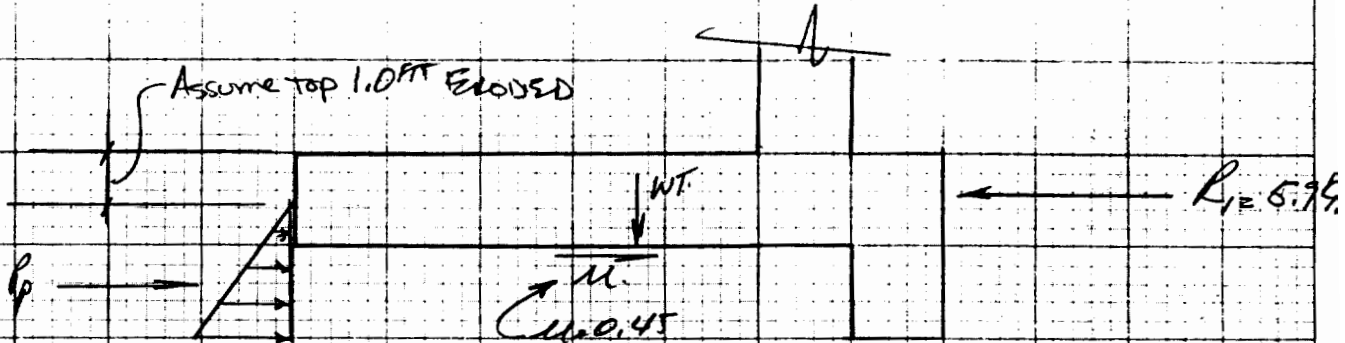

FORCES RESISTING: $\frac{1.8K + 2.8K + 9.45K + 1.8K - 9.0K}{(0.45)} = 2.97 K/FT$

PASSIVE EP. CONTRIBUTION

$$= \frac{1}{2} \gamma H^2 \tan^2 (45 + \phi/2)$$

$$= \frac{1}{2} (120) (5.0)^2 \tan^2 (45 + 32/2)$$

$$= 4.9 K/FT$$

Assume:

$$\phi = 32^\circ, C = 0$$

$$\gamma = 120 PCF$$

$$F.S. \text{ SLIDING} = \frac{2.97 K/FT + 4.9 K/FT}{5.9 K/FT} = \frac{7.87 K/FT}{5.9 K/FT} = 1.33$$

OK

Note: Although the Factors of Safety for overturning & sliding are 1.33, respectively, the conservative nature of this calculation renders the structure stable.

Rev.	Orig.	Date	Chkd.	Date	Client/Project:
					Subject:
					Calc. No. _____ Sht. _____ of _____

DETERMINE F.S. OVERTURNING & SLIDING FOR NORMAL OPERATING CONDITIONS

1.C. HEADWATERS @ 115.5

OVERTURNING $H_w = 115.5 - 105 = 10.5 \text{ ft}$

FORCES CAUSING

$$= (1/2)(62.4)(10.5)^2 = 3.4 \text{ KLF} \leftarrow$$

$$+ (1/2)(21)(62.4)(10.5) = 6.9 \text{ KLF} \uparrow$$

$$F.S._{OT} = \frac{202.95}{(3.4 \text{ KLF})(4.6') + (6.9 \text{ KLF})(14.0')} = 1.81 \text{ OK}$$

SLIDING

$$F.S._{SL} = \frac{7.87 \text{ KLF}}{3.4 \text{ KLF}} = 2.31 \text{ OK}$$

Rev.	Orig.	Date	Chkd.	Date

Client/Project: _____

Subject: _____

Calc. No. _____

Sht. _____ of _____

Aluminum Stop Logs

Introduction

Stop Logs have been used for many years to contain water in ponds, tanks, or channels. They are used in applications where their installation or removal is required infrequently. Historically, stop logs have been made from squared timbers as their name suggests. The availability of wood in the sizes, quality and quantity to make traditional stop logs has become increasingly difficult. The lack of dimensional stability in wood also makes it very difficult to provide timber stop logs with predicatable leakage characteristics.

As the following chart illustrates, Whipps series 509, 510 and 511 Stop Logs are suitable for a large range of channel widths and water depths while providing a guaranteed maximum leakage rate of .05 gallons per minute per linear foot of wetted seal. This series of Aluminum Stop Log has been in continuous production since 1980 providing an affordable and effective water flow control alternative for many types of projects.

Stop Log Application Chart
(@ 7600 P.S.I. Bending Stress)

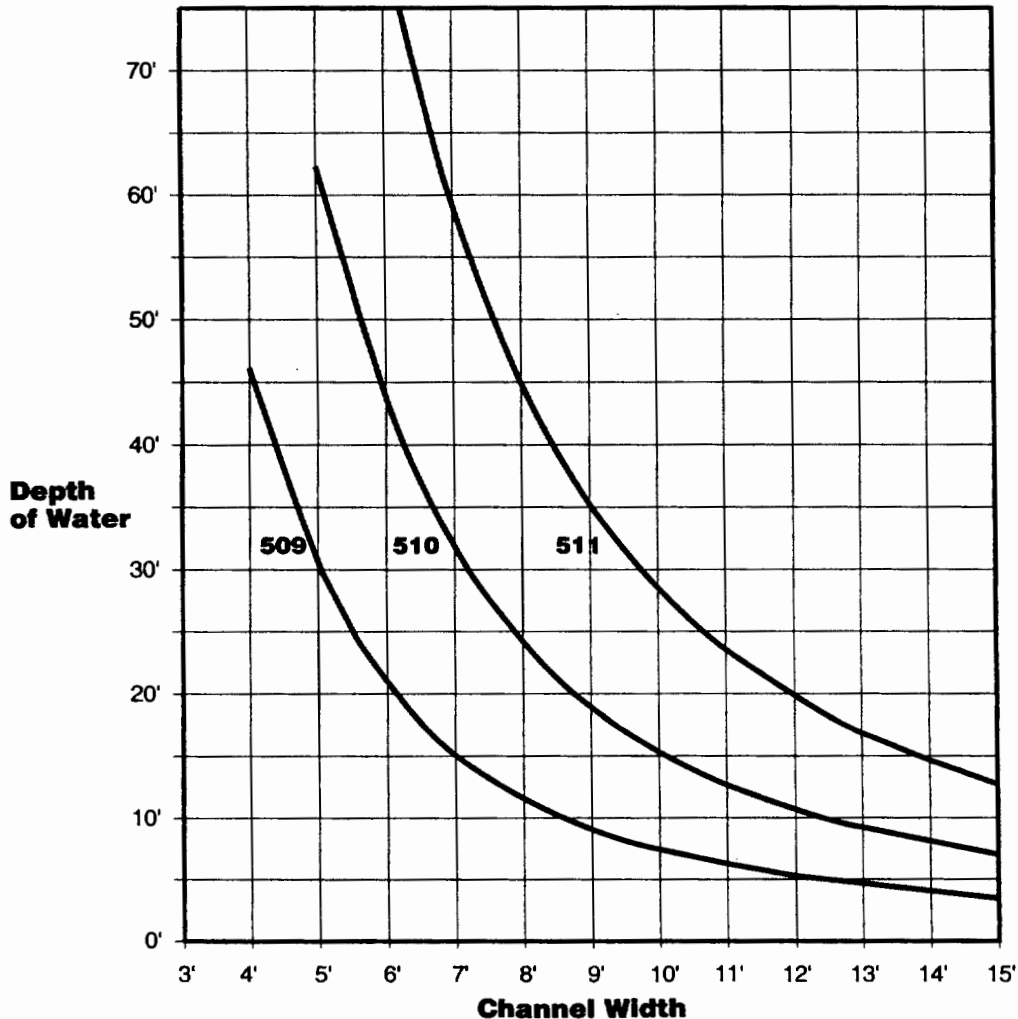

Advantages

The following pages show the standard range of stop log heights, channel widths and total water depths. Many other configurations can be designed to customize these stop logs to accommodate other stop log heights, channel widths or total water depths.

All seals are designed to provide 1/8" compliance with the groove sealing surface and also designed to seal correctly when adjacent logs are laterally offset up to 1/2". All seals are stop log mounted for ease of inspection and repair and to eliminate the potential for damage from debris that is always possible when the side seals are mounted in the sides of the stop log grooves.

The Whipps Series of Proprietary Stop Log shapes are normally carried in stock which enables outstanding delivery of stop logs, including custom designs. Stop logs of this type have demonstrated excellent service life in both water and waste treatment plant applications.

Design Features

- Stop Logs are aluminum (6061-T6), 5/16" minimum thickness and maximum 7600 psi stress.
- The specially shaped urethane seal attached to the bottom and ends of the stop logs provides an uninterrupted seal at the face of the stop log groove and the joint between the stop logs. The bottom stop log seals with the flush invert of the channel.
- The urethane seal is sufficiently compliant to deflect 1/8" under normal conditions of installation and wide enough to provide an adequate seal when adjacent stop logs are laterally offset up to 1/2".
- All contact surfaces for the stop log seals have a smooth mill finish.
- Welds on the down stream side of the stop logs are continuous.
- Adequate drainage is provided for the interior of the stop logs to prevent buoyancy or retention of water.

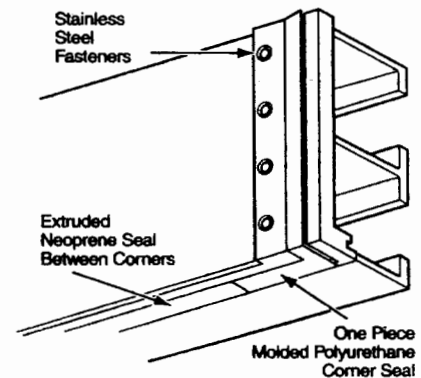

View of Typical Bottom Corner
(Model 510, 12" High Shown)

Stop Log Grooves

- **Aluminum Stop Log Grooves** are one (1) piece aluminum (6061-T6) extrusions with integral concrete anchors for embedded applications. Face mounted and channel mounted applications as shown on pages 9, 11 and 13 are also available.
- **Stainless Steel Stop Log Grooves** are a formed and welded with integral concrete anchors for embedded applications. Face mounted and channel mounted applications as shown on pages 9, 11 and 13 are also available.
- **Cast Iron Stop Log Grooves** are cast with integral concrete anchors and machined on all stop log contact surfaces. This design is for embedded applications only.

Model 509

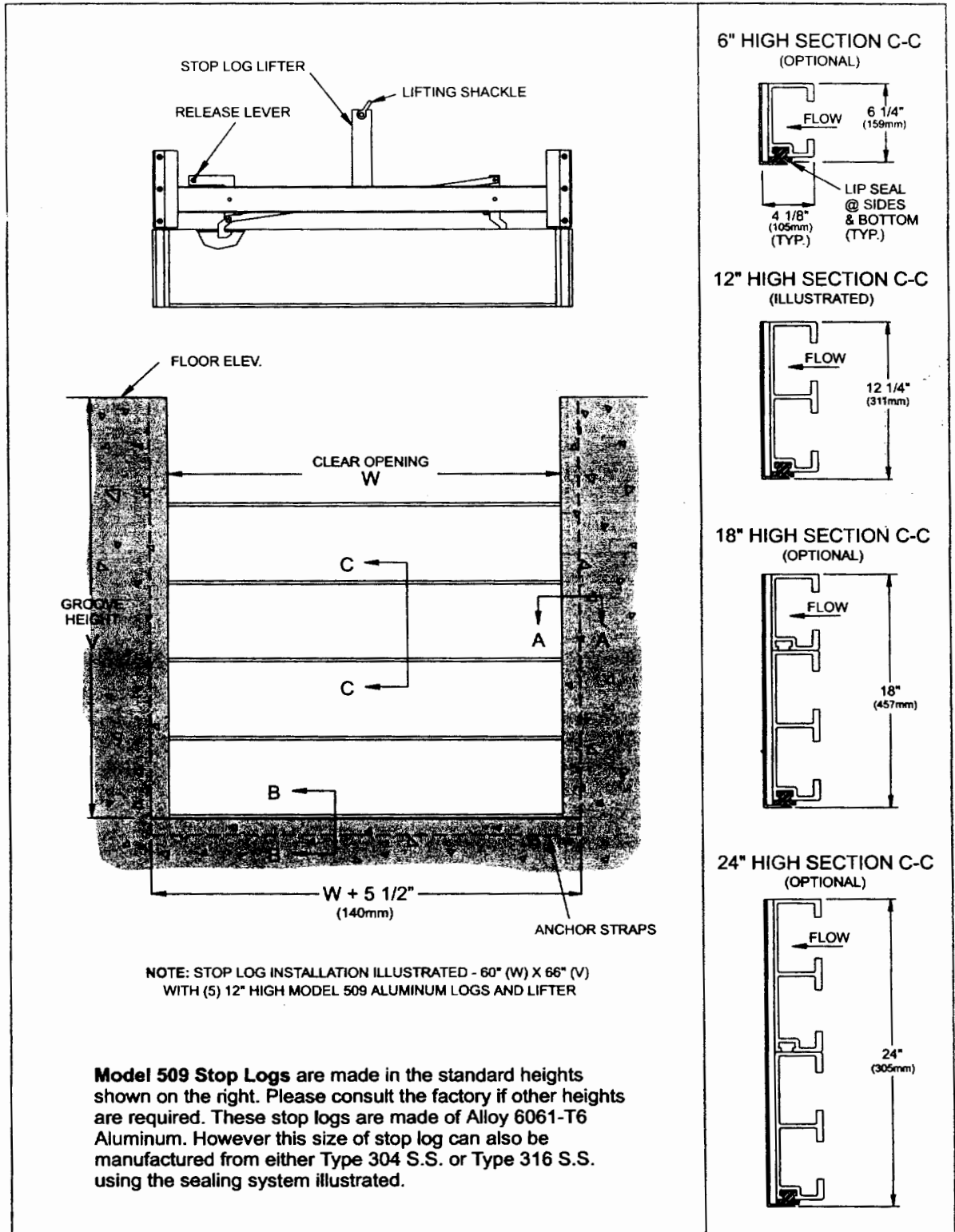

Model 509 Features

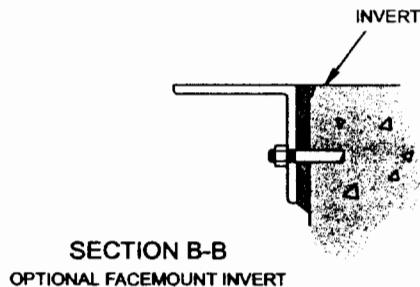
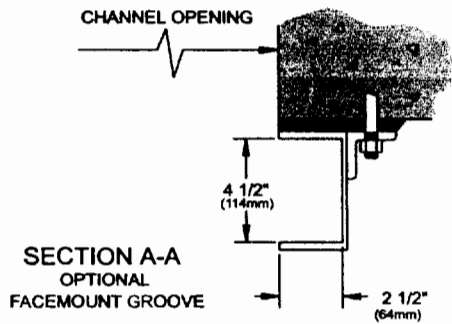
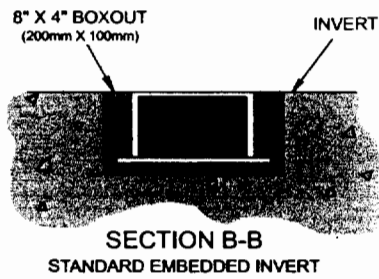
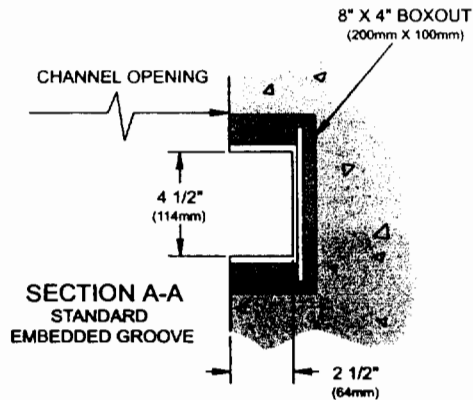

STOP LOG GROOVE FEATURES:

MATERIALS:

- EXTRUDED ALUMINUM
- FORMED STAIN. STEEL
- CAST IRON

CONFIGURATIONS:

- EMBEDDED
- FACE-MOUNTED
- CHANNEL MOUNTED

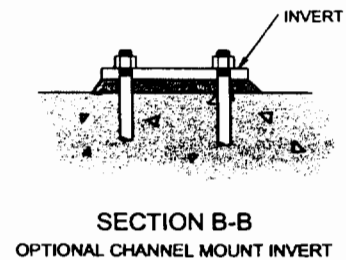
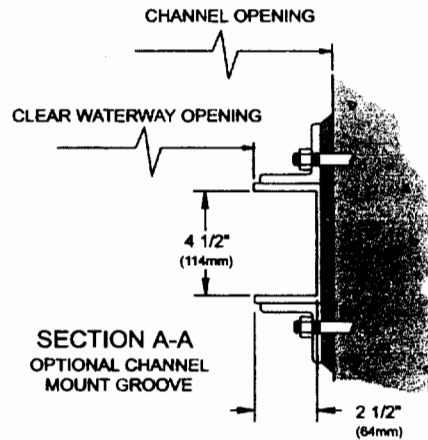

Whipps, inc.

Yoke mounting has two principal advantages: First, the gate and actuator are an integral unit which does not transmit operating thrust to the structure. Second, installation of this assembly does not require field alignment of the gate, stem and actuator.

Pedestal mounted actuators are preferred where the distance from the opening to the operating floor is relatively long, where a floor opening for the guides and yoke is not desired, or where the assembly is too large for efficient shipping and handling.

Design Features

The following chart shows the gate features indicated by each model number. These models serve the commonly specified mounting and flow configurations. Custom designs are available for applications which can not be served by these standard models.

GATE FEATURES		GATE MODEL NUMBERS											
		806	808	808-C	814	815-D	815-D-I	816	826	828	834	835-D-I	836
FRAME STYLE	Embedded	X							X				
	Face Mount		X		X	X	X	X		X	X	X	X
	Channel Mount			X									
SEALS	Side & Invert	X	X	X		X	X		X	X			
	Side, Invert & Top				X			X			X		X
MIN. MATERIAL THICKNESS	1/4"	X	X	X	X	X	X	X					
	3/8"								X	X	X	X	X
OPERATOR MOUNTING	Yoke	X	X	X	X	X	X		X	X	X	X	
	Pedestal							X					X

Optional Features

Downward Opening: All gate models can be specified for downward opening by adding a "D" to the model number. Such gates are used where there is insufficient vertical clearance to open a conventional gate or where the gate is to be used as an overflow weir. Downward opening gates may be furnished with or without a top seal (reference Model 815-D, page 14 and Model 815-D-I, page 16 and Model 835-D-I, page 26).

Interconnected Stems: All models may be specified with two interconnected operating stems by adding "I" to the model number. This type of stem arrangement is generally recommended for gates 72" or wider and having widths greater than twice their height (reference Model 815-D-I, page 16 and Model 835-D-I, page 26).

Non-Rising Stems: All models may be specified with non-rising stems by adding "N" to the model number. This operating stem arrangement is normally selected for operating installations with low headroom.

Catalog Illustrations: The twelve typical gate installations in this catalog illustrate a variety of gate models and sizes. Gate size and service conditions determine the actual gate configuration required for each new installation.

Whipps, inc.

Gate Selection Criteria

Gate Size: In water and waste water treatment plants, gates are most often sized to fit a pre-designed structure. In this regard, Series 800 gates offer great flexibility to accommodate any round, square or rectangular opening.

Gate Mounting: As shown in the model descriptions and their drawings, Series 800 gate frames may be embedded in the channel sides or mounted on the face of a wall or on the inside of an existing channel or on a wall thimble. These variations are designed to accommodate the mounting structure. Gate operation is not affected by mounting type.

Gate Material: Series 800 gates are constructed of aluminum (6061-T6 alloy) in either 1/4" minimum thickness (models 800-819) or 3/8" minimum thickness (Models 820-839)

Actuator Selection: The characteristics of the various types of actuators are discussed in the actuator section beginning on page 23. Operating loads are calculated as shown below. Manual operators should be selected to provide the calculated operating thrust with no more than 40 pounds effort. (For information regarding the selection of powered actuators, consult the factory.)

Operating load is taken as the greater of the following two quantities:

ENGLISH UNITS

1. $P = 50 h$
where
P = operating load (pounds)
h = gate height (inches)
2. $P = 12.48 A H$
where
P = operating load (pounds)
A = area of opening (sq. feet)
H = head on gate centerline (feet)

METRIC UNITS

- $P = 8756 h$
where
P = operating load (newtons)
h = gate height (meters)
- $P = 1961 A H$
where
P = operating load (newtons)
A = area of opening (sq. meters)
H = head on gate centerline (meters)

NOTE: Maximum operating loads are encountered during the first few inches of opening gate travel and the last few inches of gate travel during closing. Loads diminish quickly from these extremes.

Actuator loads transmitted to the structure: The stem thrust of pedestal mounted actuators is resisted by the structure supporting the gate and actuator. The structure must be designed to resist the maximum output of the actuator (e.g., electrical actuator at motor stall) which is necessarily greater than the operating load, sometimes much greater. Powered actuators use various devices to limit maximum output. However, the maximum output of manual actuators is only limited by the operator's effort.

Whipps, inc.

Model 806

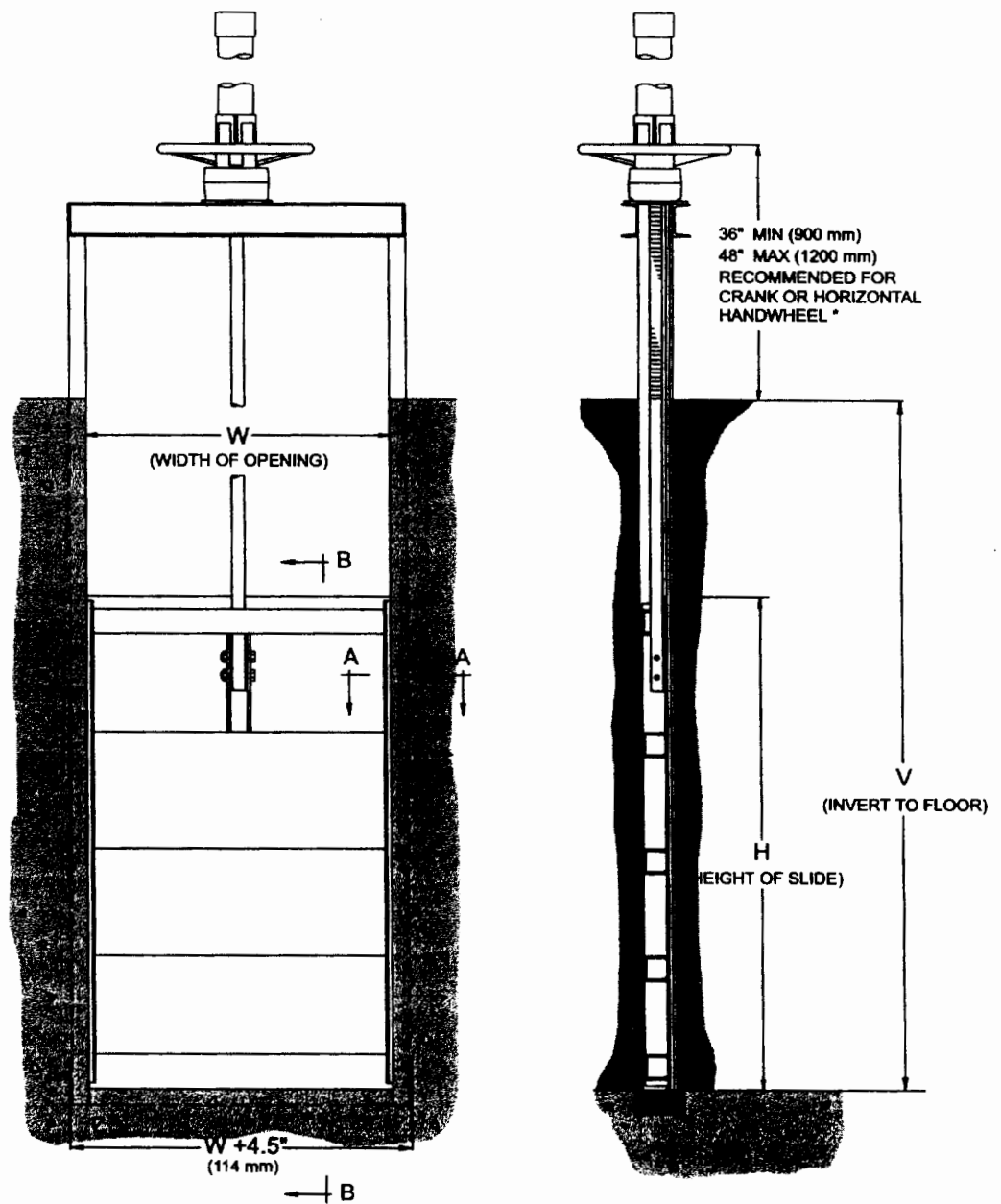

GATE ILLUSTRATED : 36" (W) x 60" (H) x 84" (V)
* SEE ACTUATOR SECTION FOR OTHER ARRANGEMENTS

Whipps, inc.

Model 806 Features

- UHMW SEATS/SEALS
- LEAKAGE AS SPECIFIED IN AWWA C501
- EMBEDDED FRAME
- OPEN CHANNEL - NO TOP SEAL
- YOKE MOUNTED ACTUATOR
- 1/4" MINIMUM MATERIAL THICKNESS
- NEOPRENE INVERT SEAL (FLUSH BOTTOM CLOSURE)

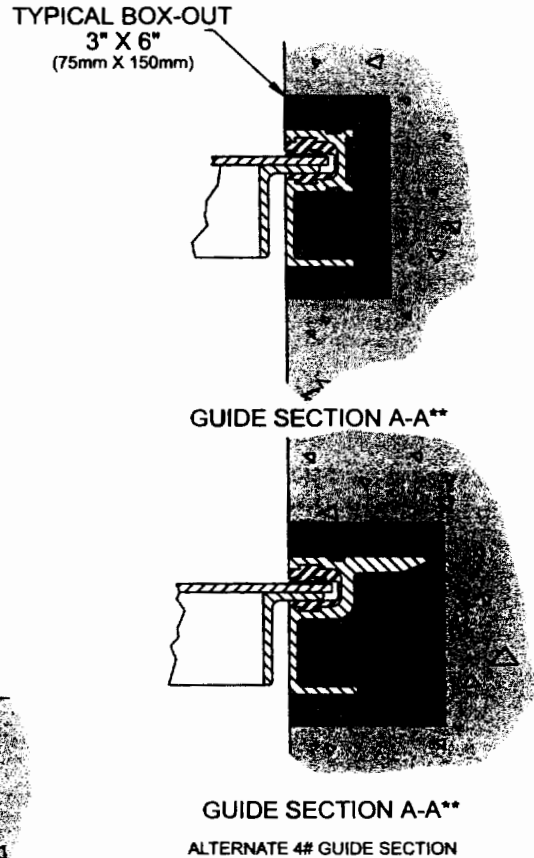
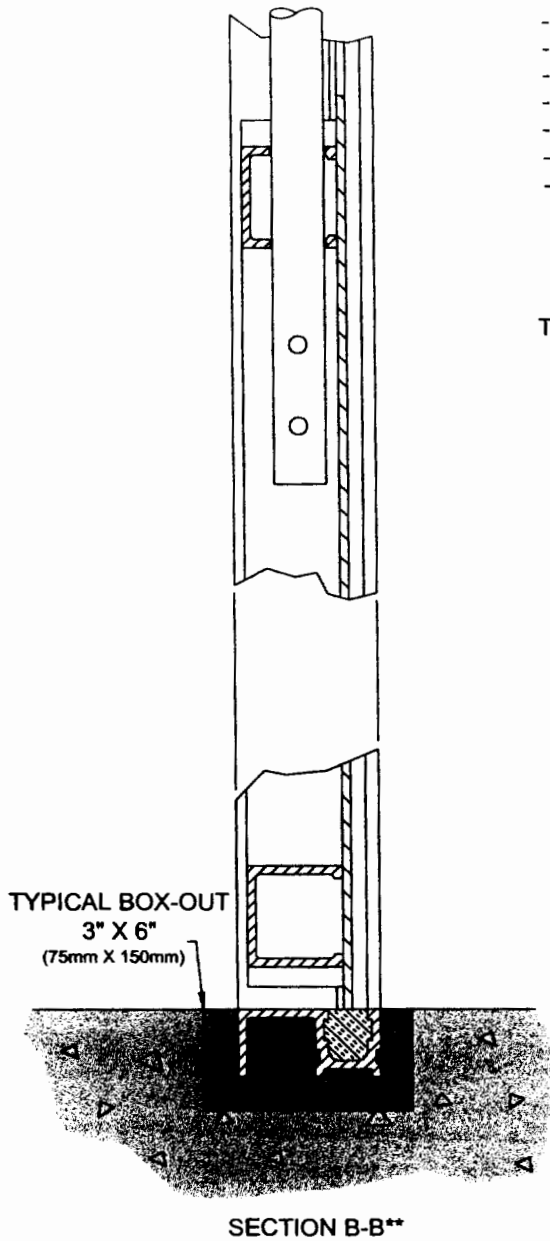

** SEE NOTE ON CATALOG ILLUSTRATIONS ON PAGE 4

Whipps, inc.

Gate Actuators

Manual Actuators: Manual actuators (handwheel or crank type) are used where operating loads are relatively low, where operation is infrequent or where electric power is not available.

The term "handwheel type" is used to denote an actuator with a handwheel directly attached to the operating nut, concentric with the stem. This drives the nut at a one-to-one ratio.

The term "crank type" is used to denote an actuator with a horizontal input shaft which drives the operating nut through a right angle gear set. Drive ratios are available to operate virtually any gate, but it should be noted that at high ratios, e.g., greater than 8:1, the time and effort to manually operate a large gate is substantial. When crank type manual actuators are to be frequently used, or when they require many turns for full gate travel, portable operators should be considered (see comments in Portable Operator section below).

Interconnected Operators:

For gates of great width relative to their height, as is common with overflow weirs, interconnected crank type actuators with a common input provide accurate positioning and smooth operation. These assemblies may be manually operated or electrically driven.

Portable Operators: Electric or gasoline powered portable operators of various configurations can be provided to drive crank type manual actuators. Consult the factory for details.

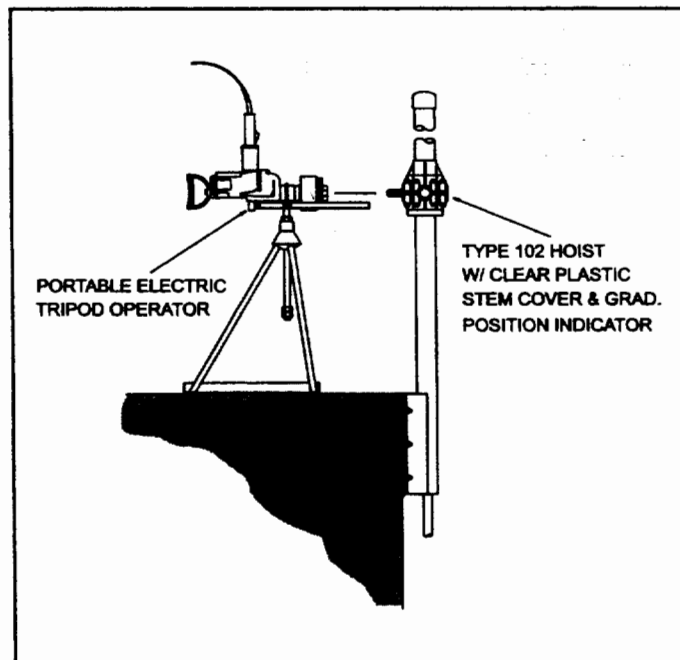

Electric Actuators: Electric actuators are used for higher loads, higher operating speed (12" - 24" per minute), or when gates are operated more frequently. Electric actuators can provide remote control of gate position and can be integrated into automatic control systems.

Hydraulic Actuators: Hydraulic actuation can provide smooth and fast operation and is particularly well suited to automatic control systems which may generate frequent modulation of the gate. With suitable accumulators, hydraulic actuators can provide automatic gate positioning upon electric power failure.

QUALITY CONTROL PLAN

Thirty-Five Percent (35%) Design Effort Fish Passage – Phase II NEW SAVANNAH BLUFF LOCK AND DAM

PROJECT SYNOPSIS

Framatome ANP DE&S (FDE&S) will complete the feasibility level design (35% percent) for the COE selected horseshoe type fish passage system at the New Savannah Bluff Lock and Dam (NSBL&D). This design effort will be executed in accordance with the five (5) primary tasks listed below. Additional details are provided in the approved work scope for Contract Number DACW01-00-D-0019, Task Order Number 0006.

- Task 1 Preferred Project Layout & Report Outline
- Task 2 Submit General Arrangement Drawings and Report Outline
- Task 3 Generate Engineering Appendix for Feasibility Design Report and Detailed Layout Drawings
- Task 4 Agency Consultation/COE Internal Review Meetings
- Task 5 Document Revisions and Final Report Submittal

PROJECT TEAMS MEMBERS

Jim Medford	Project Manager	FDE&S
Ron Grady	Civil Engineer & Technical Lead	FDE&S
Steve Arnold	Fisheries Biologist	FDE&S
Jon Truebe	Fisheries Engineer	Lakeside Engineering

INDEPENDENT TECHNICAL REVIEW TEAM

Chris Ey	Hydraulic Engineer	FDE&S
Ed Luttrell	Engineering Manager	FDE&S
Mike Murphy	Project Manager	FDE&S

SCHEDULE

Task 1 – Preferred Project Layout

- Review Existing Data (Week 1)
- Request Additional Data/Information (Week 1)
- Submit Quality Control Plan (Week 1)
- Perform Hydraulic Analysis (Weeks 2-4)
- Perform Earthwork and Geotechnical Studies (Weeks 2-4)
- Determine Recommended Canal Alignment Configuration (Weeks 2-4)
- Design the Headwater and Tailwater Structure Configurations (Weeks 2-4)
- Determine Project Access Requirements (Weeks 2-4)
- Identify Potential Sources of Construction Materials (Weeks 2-4)

Determine Excavated Material Disposal Requirements (Weeks 2-4)
Develop Annotated Draft Engineering Appendix Outline & Prel. Drawings (Weeks 5)

Task 2 - Submit General Arrangement Dwgs & Draft Report Outline (Week 6)

Task 3 - Draft Engineering Appendix for the Feasibility Report & Detailed Layout Drawings (Weeks 7-9)

Project Feasibility Design
Project Schedules
Quantity Estimates and Cost Estimates

Task 4 - Agency Consultation & ITR (Weeks 10-11)

Task 5 - Document Revisions and Final Report Submittal (Weeks 12-13)

Listed below is documentation of the ITR provided by Mr. Steve Arnold (Fisheries Biologist), substituted for Mike Murphy (as approved by Mr. Maurice James USACE).

Steve - My response to your comments is listed below. Please note that Jon will address the issue of gate flow velocities. Thanks again and let me know if you have further questions.

Ron Grady
Sr. Project Engineer
Hydropower & Natural Resources

-----Original Message-----

From: ARNOLD Stephen
Sent: Tuesday, December 03, 2002 12:03 PM
To: GRADY David R
Cc: Truebe, Jon (E-mail)
Subject: New Savannah Bluff Lock & Dam Technical Review

Ron

As you requested in your letter of 12/5/02, I have completed your requested internal technical review on the Draft Fish Passage Report for the New Savannah Bluff Lock & Dam. I have reviewed the report both from a technical perspective and also offer editorial comments. My comments are listed below:

- p.2, Task 3, last sentence, anticipate s/r anticipated **[GRADY David R]** (Completed)
- p.9, C.3. 1st para., last sentence, insert Phase I after the word draft **[GRADY David R]** (Completed)
- p.12, 2nd. para., 7th line, says "design maximum head of 17 feet", but p.20 says 17.5 feet **[GRADY David R]**

The report will reference the following operating pond elevations and resulting design differential heads:

Headwater:

High Headwater Operating Level - 115.5
Normal Headwater Operating Level - 114.5
Low Headwater Operating Level - 113.5

Tailwater:

Normal Tailwater Operating Level - 101.5
Extreme Low Tailwater Operating Level - 98.0

Resulting Design Heads:

Normal Design Head - 14.0 feet
Extreme Maximum Design Head - 17.5

- p.13, Section C, 2nd para., says " maximum head is estimated at about 17 feet", but p.20 says 17.5 feet **[GRADY David R]** (See Note above)
- p.16, 1st line, 1996 s/r 1998 **[GRADY David R]** (Completed)
- p.20, Section B.1.3.3, 2nd sentence, says "The maximum head is 115.5 feet minus 98 feet, or 17.5 feet.", but pp.12 & 13 say 17 feet **[GRADY David R]** (See Note above)
- p.20, references to Figures 4, 5, and 6 are out of sequence. **[GRADY David R]** Noted
- p.21, 2nd para., next to last sentence, delete extra period at end **[GRADY David R]** Completed

- p. 21, bottom of page, Table of head gate velocities, shows velocity through the head gates of approximately 2.94 to 3.75 ft/sec. Given this is the only place in the fishway where velocity is relatively uniform across the entire fishway channel, are these velocities suitable for passage of all target species ? It seems to be a little high. **[GRADY David R]** (Jon Truebe to address under separate cover)
- Appendix D is empty. Are Material Quantity estimates presented elsewhere in the report? **[GRADY David R]** (Correct and Noted)
- Appendix F. Delete the "DRAFT" in the upper right hand corner. These are Final Meeting Minutes. **[GRADY David R]** (Completed)

If you have any questions regarding these comments, please give me a call.

Steve Arnold

Stephen H. Arnold
Senior Aquatic Scientist
Framatome ANP DE&S
500 Washington Ave.
Portland, Maine 04103
Phone: (207) 775-4495
email: (NEW)
stephen.arnold@framatome-anp.com

Listed below is documentation of the ITR provided by Mr. Ed Luttrell (Engineering Manager, Framatome ANP-DE&S).

Ed - Your comments have been incorporated into the subject report

Thanks
Ron Grady
Sr. Project Engineer
704-805-2787

-----Original Message-----

From: LUTTRELL Ed C
Sent: Monday, December 09, 2002 4:32 PM
To: GRADY David R
Subject: FW: Report Review

I will be in a meeting until mid-day Monday, so I am sending these comments from home .. The report looks good, comments are mostly editorial.

ED

Pg 2, Task 3: "It is also anticipatedd that the ..."

Pg 8, C.1, 8th line: "...during a meeting..."

Pg 9, C.3, 4th Para: how about complicated vs. compounded

Pg 10, 3rd Para: no comma after horseshoe design

Pg 12, B.1, 1st Para: The borings were advanced to depths of (vs. have)

Pg 12 : Through out report you switch between x.0 and just x for elevations, be consistent

Pg 13, B.2, 3rd bullet: confirm listing status, federal ? state ? rare, threatened, endangered ?

Pg 13, C., 2nd Para: I would not say "slightly underestimate" without data, what about striking slightly

Pg 14 1st Para: Are all upstream flows from generation, no accretion flow or spill ?

Pg 15, A.1: you cap. Resource Agencies one place and not another

Pg 16, last line: "...and is not a design..."

Pg 20, B1.3.2: footnote 1 is not needed since table calls out avg. velocity

Pg 21, 2nd Para: should it be expected to **reduce** (vs. remove)

Pg 23, B.1.3.7, 2nd bullet: congregated (noting)

Pg 24, B.1.4, 1st Para: drawings are numbered SAVANNAH1,2,3, etc.

Pg 24, B.1.4, 2nd Para: delete one "are placed" and pattern, not patter

Pg 24, B.1.4, 3rd Para: "protected **from** erosion **by** a 2 ft"

Pg 24, B.2.1, 3rd bullet: suggest "vehicle" instead of "rolling stock"

Pg 25, B.2.3: is, not id

Pg 26, 1st Para, 5th line: lowered, not lower

Pg 26, 2nd Para: suggest "minimum (reinforcing needed for crack control)."

Pg 35, B.3.1, 2nd bullet: suggest "with equipment" versus "via rolling stock"

Pg 37, 2nd Para: suggest "existing" trees versus "natural trees (is there any other kind ?)

Is the hydrostatic pressure right on Figure 9 ???

On drawing 1, should you label the heavy dash-dot line is it property boundary ??

On drawing 2, note in lower left should be WATER WAS TOO SHALLOW, not TO

**Listed below is documentation of the ITR provided by Mr. Chris Ey
(Civil /Hydraulic Engineer, Framatome ANP-DE&S)**

Ron,

Per your request, I have reviewed the Savannah Bluff Draft Engineering Report dated November 2002. Based on my review the report appears to be prepared in accordance with standard engineering industry practice. I do not have any specific technical comments. I noted several editorial -type recommended corrections on the draft copy I reviewed. Please review and incorporate as appropriate.

Chris

-----Original Message-----

From: GRADY David R
Sent: Monday, December 02, 2002 5:19 PM
To: ARNOLD Stephen; EY PE Chris; LUTTRELL Ed C
Subject: Savannah Bluff - Internal Technical Review

Steve - Here is the letter we talked about. Please provide me with your written comments.

Ed and Chris, we can discuss on Thursday.

Ron Grady
Framatome ANP DE&S
400 South Tryon Street
Charlotte NC 28285
Phone: 704-805-2787
email: ron.grady@framatome-anp.com

<< File: Internal Review - December 5.doc >>

**Listed below is documentation of the internal client review provided by
Mr. Maurice James (USACE Engineer)**

Maurice - Your comments have been incorporated into the subject report. Thanks and let me know if you have any questions.

Ron Grady
Sr. Project Engineer
704-805-2787

-----Original Message-----

From: Maurice.James@sam.usace.army.mil [mailto:Maurice.James@sam.usace.army.mil]

Sent: Monday, December 09, 2002 10:04 AM

To: Ron.Grady@framatome-anp.com

Subject: RE: NSBL&D Fishway Draft Engineering Report Comments

Ron,

Attached are my comments. I think you have them from the meeting but this will give you a reference and make it "official".

MJ

-----Original Message-----

From: GRADY David R [mailto:Ron.Grady@framatome-anp.com]

Sent: Thursday, December 05, 2002 1:19 PM

To: Maurice James (E-mail)

Cc: William G. Lynch (E-mail)

Subject: NSBL&D Fishway Draft Engineering Report Comments

Maurice - As discussed, please forward to me any pertinent internal COE comments to the draft report.

Thanks

Ron Grady
Framatome ANP DE&S
400 South Tryon Street
Charlotte NC 28285
Phone: 704-805-2787
email: ron.grady@framatome-anp.com

Appendix K Other Miscellaneous Information



Location: Bad Bodendorf, Germany

River: Ahr

Type: rock ramp fishway

Slope: 1:25

Headloss: 1.60m

Width: 25m

Flow: 1.20m³/s min. to 9.60m³/s

Designer: Gerbler

Picture Source: Uli Dumont





Location: St. Laurent des Eaux, France
River: Loire
Type: step-pool rock ramp fishway
Slope: 1:50
Headloss: 16in max. per step, 6ft dam height
Width: 52.8ft
Length: 264ft
Flow: 63-835cfs (design), 12,670cfs (mean annual)
Designer: Travade
Picture Source: Travade



Location: near Churchill, Canada

River: Churchill

Type: rock ramp fishway

Slope: 1:30

Headloss: 1.8m, 2m dam height

Width: 2.3km long weir, 300m wide ramp

Flow: 75m³/s (min.), 150cfs (10%ile Sept.)

950m³/s (90%ile open water), 1500m³/s (100yr)

Designer: Manitoba Hydro

Picture Source: Chris Katopodis